

0003701

CYPRUS ANVIL MINING CORPORATION

DRILL-HOLE DATA HANDLING SYSTEM

(Short Notes, for all Geologists Logging C.A.M.C. Core)

Compiled by:

B. V. Hall, C. W. Jefferson,

D. S. Jennings, D. B. Kilby,

J. R. Marlon-Lambert,

and L. C. Pigage

May, 1981

DRILL-HOLE DATA HANDLING SYSTEM
TABLE OF CONTENTS

	<u>PAGE</u>
1. INTRODUCTION	1
2. DRILL-HOLE DATA FORMATS	2
3. CAMC1981-E-1 OF DIAMOND DRILL CORE LOGS	4
3.1 Drill-Hole Identification and General Parameters	4
3.2 Sample of Page CAMC1981-E-1	5
4. PAGE CAMC1981-E-2 OF LOGS: LOCATION, SURVEYS, COMMENTS	6
4.1 Type "T" Data (Drill-Hole Header Data)	6
4.2 Type "R" Data (Down-Hole Survey Data)	7
4.3 Figure 4.3 Definition of Down-Hole Survey Angles	8
4.4 Type "C" Data (Comments)	9
4.5 Sample of Page CAMC1981-E-2	10
5. PAGE CAMC1981-E-3 OF LOGS: LITHOLOGY	11
5.1 Type "L" Data (Lithology Data)	11
5.1.1 Lithologic Units for Gataga Area	12
5.1.2 Lithologic Units for Anvil District	12
5.1.3 Lithologic Units for New Projects	12
5.2 Sample of Page CAMC1981-E-3	13
5.3 Sample of Page CAMC1981-E-3A	14

TABLE OF CONTENTS (cont'd)

	<u>PAGE</u>
6. PAGE CAMC1981-E-4 OF LOGS: STRUCTURE	15
6.1 Type "S" Data Card (Geological Structure Data)	15
6.1.1 Sample of Page CAMC1981-E-4	17
6.2 Symmetry Codes	18
6.2.1 Zone Observations	18
6.2.2 Point Observations	20
6.2.3 Sample Computer Plot of S_0 and S_1 at 1:1000 (1980 & 1981)	22
6.2.4 Sample Computer Plot of S_1 at 1:1000 (1980 version)	23
6.3 Structural Synthesis (or antithesis)	24
6.3.1 Dip Line Azimuths and the Right Hand Rule ...	24
Figure 6.3.1: Right Hand Rule	26
6.3.1.1 Example 1 (Cirque)	27
Figure 6.3.1.1	28
6.3.1.2 Example 2 (Cirque)	29
Figure 6.3.1.2	29
6.3.1.3 Example 3 (Cirque)	30
Figure 6.3.1.3	30
6.3.1.4 Example 4 (Anvil District)	31
Figure 6.3.1.4	31
6.3.2 Symmetry Determination	33
6.3.2.1 Examples of symmetries in core	35
6.3.2.2 Example of structural synthesis	37
7. PAGE CAMC1981-E-5 OF LOGS: ASSAY SAMPLES	38
7.1 Type "P" Data Card - Assay Log (Sample Location)	38
7.2 Sample of Page CAMC1981-E-5	39

TABLE OF CONTENTS (cont'd)

	<u>PAGE</u>
8. PAGE CAMC1981-E-6 OF LOGS: RESEARCH SAMPLES	40
8.1 Type "H" Data Card - Research Sample Field Sheet	40
8.2 Sample of Page CAMC1981-E-6	40
8.3 Research Sample Logs	40
8.4 Sample of Research Sample Log CAMC1981-E-7	41
8.5 Sample of Thin Section Log CAMC1981-E-8	41
 9. REFERENCES	 43
 APPENDIX I: GRANDFATHERED METHOD OF MEASURING STRUCTURAL ELEMENTS IN DRILL CORE	 44
Grandfathered Example 1 (Cirque)	45
Grandmothered Example 2 (Cirque)	47
Ancient Example 3 (Cirque)	48
Great-Grandfathered Example 4 (Anvil District)	 49
APPENDIX II: LITHOSTRATIGRAPHIC COLUMN, GATAGA AREA	51
APPENDIX III: LITHOSTRATIGRAPHIC COLUMN, ANVIL AREA	55
APPENDIX IV: DRILL-HOLE IDENTIFICATION CODES, 1981	58

1. INTRODUCTION

Geologic information is collected at great expense and considerable risk during exploration and development drilling programs on orebodies. Cyprus Anvil has a computerized drill-hole data management and display system which is designed to store, retrieve and graphically display this information. After drill-hole data has been input to the computer and verified it is readily accessible and not subject to further transcription or re-interpretation of errors.

To facilitate computerization, the drill logs are recorded, in the field, on standardized forms. There are six page types used for all logs. Care must be taken to record all of the information properly, otherwise the geologist will have to spend much additional time on his logs and lengthy delays will result from having to run computer plots of drill-hole profiles more than once. Small omissions or errors made in the field may seem insignificant until they are multiplied many hundreds of times by a number of people on a large drill program.

These short notes are condensed from General System Notes prepared by J. R. Marlon-Lambert (July, 1980).

2. DRILL-HOLE DATA FORMATS

The drill-hole data consist of a number of observations taken at intervals along the length of the drill-hole. The data recorded on the (pre-printed) field sheets are entered into the computer system either from keypunched cards or via low-speed terminal input. Each observation is entered as a separate data record (one per key-punched card or one per low-speed terminal line image). The format of the data card varies for each type of observation and each data type is identified by a special character code which is punched in the first column in a card or typed in the first column of a line image. These codes and their associated data types are defined below:

<u>CODE</u>	<u>TYPE OF DATA</u>
T	header record for collar coordinates and elevation
C	remarks
R	down-hole survey data -- azimuth and inclination in terms of the zenith angle measured in decimal degrees
L	lithologic data
S	structure data
P	sample location data giving interval and sample number
A	assay data, type 1
M	assay data as recorded for the Faro mine model analysis (used by the MINTEC open-pit mine design programs)
H	hand sample for research purposes, giving interval and sample number

Note the appropriate code letter must appear in column 1 of the field sheet for each data entry or else the information will not be keypunched. This gives the geologist the flexibility of recording supplementary information without it necessarily being displayed on a drill-hole plot. The data and format for each of the above codes are described in detail in the following pages. Coding formats and keypunching instructions are contained in Appendix III of Marlon--Lambert (1980).

3. PAGE CAMC1981-E-1 OF DIAMOND DRILL CORE LOGS

3.1 Drill-Hole Identification and General Parameters

Information to be collected for each drill-hole starts with the individual drill-hole identification code and the collar coordinates. Other useful subsidiary information is recorded as shown on the following sample of a summary field sheet for the diamond drill-hole. The summary field sheet for the diamond drill-hole should be kept up to date as the hole progresses.

Drill-hole identification codes are composed of up to seven (7) alphanumeric characters. Intermixed alphabetic letters, numbers and even symbols may be used. The current Cyprus Anvil usage generally reserves the first character for Department, the second for Project, the next two characters for the year in which the hole was drilled, another character to denote the deposit and two more characters for the number (in the year) of the hole. An example from the Cirque deposit drilling program in 1979 is: "EG79-C-14" (Exploration-Gataga 1979-Cirque-Hole No. 14). Any 1981 Feasibility and Development holes could be labelled "FG81-C-02". This drill-hole identification is used for all data collected from this hole and is recorded on every page of the drill log. Codes for all 1981 projects are listed in Appendix IV.

CYPRUS ANVIL MINING CORPORATION

DIAMOND DRILL CORE LOG

Date: May 15, 1981

Hole Number: EG-81-C-01

Reference Fabric Orientation Diagram:

Project: GATAGA

Location: CIRQUE GROUP

Claim: CIRQUE # 1

Terr. Plane Co-ords.: 6 375 331.59 N

370 366.00 E

Grid Co-ords: _____

Inclination: Vertical

All symmetry determinations looking

Elevation: 1 832.9

NW with S_i dipping

Total Depth: 617.8 m

SW with dip azimuth 210°

Purpose: To test down-dip extension of ore

Reason hole Terminated: Intersected ore and footwall Silurian Siltstone

Logged by: DK, WR, CJ, LCP, VZS Date(s) Logged: May 16, 17, 19, 30 1981

Drilling Contractor: J. T. Thomas

Size	CORE From	To	Collar Cased and Capped:
CASING	0	10 m	<u>No</u>
NQ	10	500	
BQ	500	710	

Hole Cemented: Yes

Steel down hole: No

Started: May 15/81 Completed: May 30/81

4. PAGE CAMC1981-E-2 OF LOGS: LOCATION, SURVEYS, COMMENTS

4.1 Type "T" Data (Drill-Hole Header Data)

This data record is the drill-hole header and must always be the first computer record of the set of data for a drill-hole. The record contains the drill-hole identifier, collar elevation, collar coordinates and the system of measurement (feet or meters). The data format is as follows:

- col 1 -- card code -- "T"
- col 2-8 -- drill-hole identifier of 1-7 alphanumeric characters (see page 3). All other data for this drill-hole must have this identifier or they will be rejected.
- col 10-16 -- collar elevation
- col 17-24 -- collar northing coordinate
- col 25-32 -- collar easting coordinate
- col 34-39 -- units of measurement for the depths and coordinates. FEET or METERS If field blank meters are assumed
- col 41-42 -- R.F.E. - reference fabric element - for symmetry determination, e.g. S1, S2.

NOTE: Col 10-16, 17-24, 25-32 and 41-42 must be entered. If not available, dummy values should be input. e.g. zeros

When the data are entered all alphanumeric fields are left justified in their fields while the numeric fields (elevation and coordinates) are right justified with the decimal implied at the end of the field if it is not entered with the data.

The field sheet used to record drill-hole header ("T") data also contains down-hole survey ("R") data and geologists' comments ("C" data). An example of this multi-purpose form follows the section describing type "C" data.

4.2 Type "R" Data (Down-Hole Survey Data)

This record is used to enter survey data measured at intervals down the drill-hole. The survey data (Figure 4.3) consist of the borehole azimuth, relative to true North; and the borehole inclination entered as a zenith angle defined as follows:

- 0 vertically upwards
- 90 horizontal
- 180 vertically downwards

All angles are measured in decimal degrees.

Note: At least one survey record must be present in the set of data for a borehole giving the azimuth and inclination at the collar. (Unless the hole is inclined, these are normally 0 and 180 degrees, respectively). The collar azimuth of vertical holes should be assigned the same value as the first survey, otherwise the computer will assume the hole is headed towards 000°.

Entries of "R" data are made in the following format (see example on page II):

- col 1 -- card code -- "R"
- col 2-8 -- drill-hole identifier; this must be the same as on the type "T" header record
- col 10-14-- depth at which the measurement was made and is entered as an integer in units of 0.1 feet or meters i.e. 02500 -- 250.0
- col 15-20-- to-depth; not used
- col 22-26-- the drill-hole inclination measured at the depth and entered as a zenith angle as defined above. The angle is in terms of decimal degrees and must be entered with the decimal point to the nearest 0.1 degrees. (See Figure 4.3)
- col 28-32-- the drill-hole azimuth measured at the depth. This angle is measured clockwise from true north. The angle is measured in decimal degrees and is entered the same as the inclination.
- col 35-56-- optional comment field

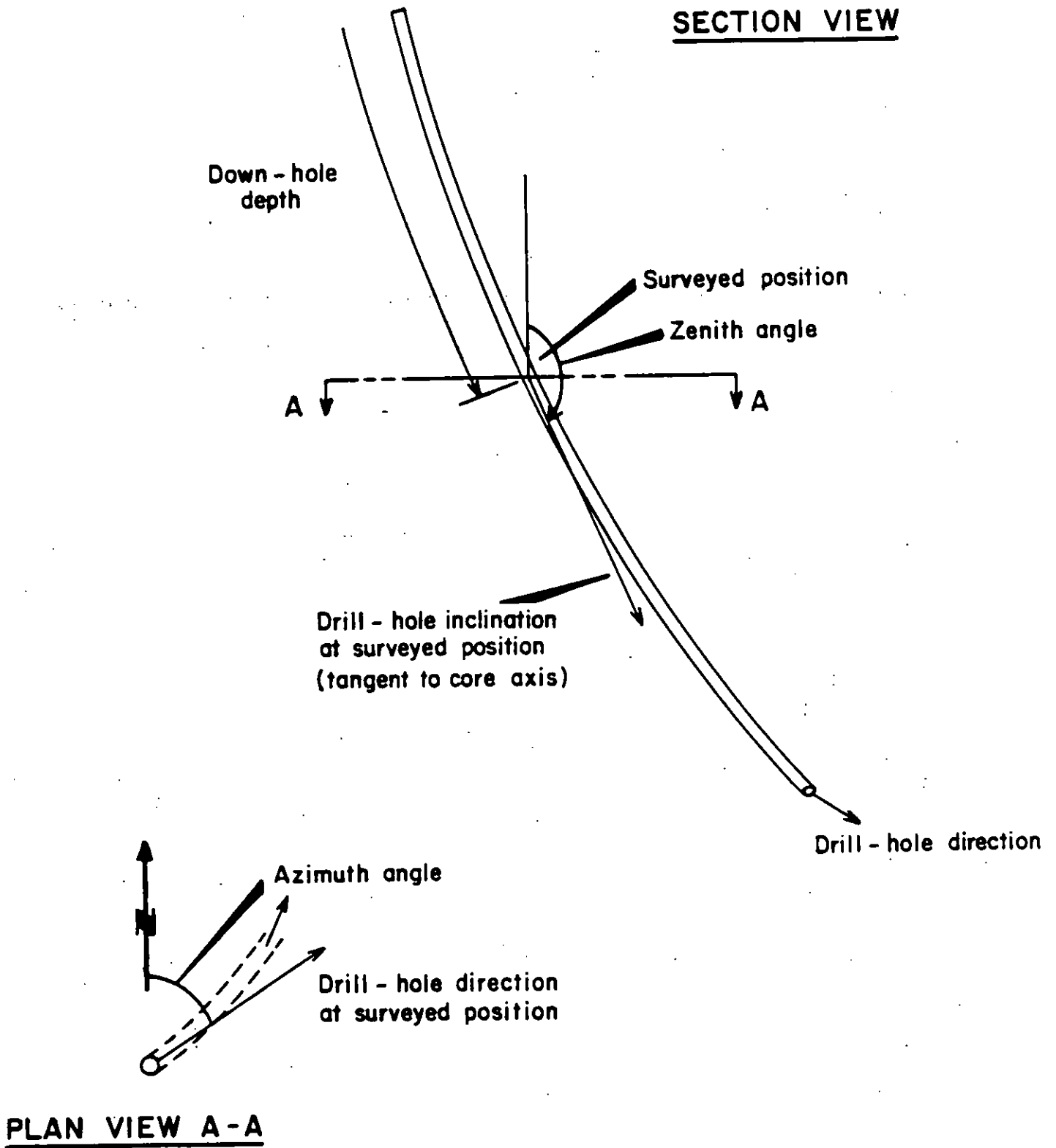

Figure 4 - 3 DEFINITION OF DOWN - HOLE SURVEY ANGLES

4.4 Type "C" Data (Comments)

This record is used to store comments about the drill-hole.

The format of the record is as follows:

- col 1 -- card code -- "C"
- col 2-8 -- drill-hole identifier; this must be the same
 as the type "T" header record.
- col 10-51 -- comment text field. This may contain any ex-
 planatory notes the geologist cares to add to
 to the quantitative data.

Cyprus Anvil Mining Corp.

Page 2 of _____

DDH E.G.8.1.C.0.1
2 8

Diamond Drill Core Log

Date: May 15/81 Logged By: DK, WR, CWJ,
LCP, VZS

Code	Drillhole	Elevation	Northing	Easting	Units (feet/metres)	R.F.E						
1	2	8	10	16	17	24	25	32	34	39	41	42
T	E.G.8.1.C.0.1	1,832.9	63,753.3	2	37,036.6	METRES	S.1					

Code	Drillhole	Depth	Zenith Angle	True Azimuth	Comments												
1	2	8	10	14	22	26	28	32	34	36	38	40	42	44	46	48	50
R	E.G.8.1.C.0.1	00	180.0	0	01.0.0	AT COLLAR											
R	E.G.8.1.C.0.1	305	176.5	0	01.0.0												
R	E.G.8.1.C.0.1	914	152.0	0	180.0	DO NOT TRIVISIT THIS											
R	E.G.8.1.C.0.1	1,524	170.0	0	012.0												
R	E.G.8.1.C.0.1	2,134	156.0	0	022.0												
R	E.G.8.1.C.0.1	2,743	150.0	0	018.0												
R	E.G.8.1.C.0.1	3,353	148.0	0	023.0												
R	E.G.8.1.C.0.1	3,962	145.0	0	015.0												
R	E.G.8.1.C.0.1	4,572	144.0	0	013.0												
R	E.G.8.1.C.0.1	5,182	142.0	0	022.0												
R	E.G.8.1.C.0.1	5,760	140.0	0	018.0												
R	E.G.8.1.C.0.1	6,413	140.0	0	015.0												
R	E.G.8.1.C.0.1	7,051	138.0	0	013.0												

Code	Drillhole	Comments, Errant Remarks, Snivellings and / or Lewd Suggestions																				
1	2	8	10	14	16	18	20	22	24	26	28	30	32	34	36	38	40	42	44	46	48	50
C	E.G.8.1.C.0.1	SPEERRY SPIN READING SUSPICIOUS AT 91.4 POSSIBLY HUNG UP IN DRILL RODS																				

5. PAGE CAMC1981-E-3 OF LOGS: LITHOLOGY

5.1 Type "L" Data (Lithology Data)

This type of page is used to enter the sequence of lithologic units observed over the length of the drill-hole. The format of the record is as follows:

- col 1 -- card code -- "L" (must accompany any data to be key-punched).
- col 2-8 -- drill-hole identifier; this must be the same as on the type "T" header record
- col 10-14 -- beginning 'From' depth of the lithologic unit. The depth is entered in units of 0.1 feet or 0.1 meters as an integer number; i.e. 1500 is 150.0 Where 'From' is not entered it is assumed to be the same as the 'To' of the preceding "L" entry.
- col 16-20 -- ending 'To' depth of the lithologic unit. This depth is entered in the same manner as the beginning depth
- col 22-24 -- recovery in metres (feet) giving length of core actually in core box. If left blank, value is set at -0.5 to indicate not measured.
- col 26-28 -- Number of lithologic entry, for organization and retrieval use. This has always been an integer sequence number, in increasing order from the unit directly beneath the collar, beginning with 001
- col 30-34 -- lithologic unit. These units are assigned by the project geologist to cover all rock types expected to be encountered
- col 35 -- verbal description of unit, not keypunched. Extra modifiers of lithologic units can be inserted at the beginning of this space.

5.1.1 Lithologic Units for the Gataga Area

The lithologic unit is designated by a five character code:

char 1,2 -- alphabetic (A-Z), denoting AGE (e.g. D = Devonian),
GROUP or FORMATION (e.g. G = Gunsteel)

char 3,4 -- alphabetic (A-Z) denoting rock type or member (e.g.
PH = phyllite, hanging wall)

char 5 -- alphabetic (A-Z) or blank denoting modifier (e.g.
B = barite nodules)

- any additional modifiers are not coded but can be placed
in the Description space for visual access.

Details of lithologic units including OVERBURDEN and FAULTS are given
in the lithostratigraphic column used for the Gataga District (Appendix
II).

5.1.2 Lithologic Units for the Anvil Area

The lithologic unit is designated by a five character code:

char 1;2 -- alphanumeric denoting AGE or FORMATION

char 3 -- alphabetic (A-Z) denoting member

char 4,5 -- alphanumeric (A-Z) denoting modifiers, left justified
and in decreasing order of importance.

e.g. |4| |A|4|5|

Details of lithologic units are given in the lithostratigraphic column
used for the Anvil District (Appendix III).

5.1.3 Lithologic Units for New Projects

Manager(s) of new projects will be responsible for designating
lithologic units for their areas, using a left-justified 1 to 5 cha-
racter code. Page CAMC1981-E-3A is used because it allows more room
for description. Structural observations can be included with the
lithologic descriptions. It is still compatible with the computer
system but need not be computerized in the early stages of projects
that may not be successful. Examples of pages 3 and 3A follow.

6. PAGE CAMC1981-E-4 OF LOGS: STRUCTURE

6.1 Type "S" Data Sheet (Geological Structure Data)

This field sheet is used to record structural observations from the drill-core. As these are structural data, the observations are assumed to be at discrete points down the drill-hole. The depth of observation is always taken to be the "to-depth". The data that may be observed may include: structural features; symmetry data; orientation of S_1 and/or S_2 planes with respect to the core axis. The format of the data card is as follows:

- col 1 -- card code -- "S"
- col 2-8 -- drill-hole identifier which must be the same as used on the header card (type "T") for this drill-hole
- col 10-14 -- from-depth of the observation. This depth is not required but if present is recorded to the nearest 0.1 foot with the decimal point assumed between columns 13 and 14
- col 16-20 -- to-depth of the observation. This depth must be present and is taken as the depth at which the observation was made. The depth is recorded in units of 0.1 feet with the decimal point assumed between columns 19 and 20.
- col 22-24 -- this field has been traditionally used to insert descriptive information about structural features in the early learning stages of a project. It is often left blank and is not plotted. Any 3 alphanumeric descriptors can be used. Examples that have been used include: PS2, pervasive S2; CS2, crenulation S2; IND, indeterminate symmetry; DD, fold axis is down-dip; F2, phase 2 fold; F0, sedimentary fold. As we progress, some of these features "graduate" to the symmetry code in column 26. For example, IND includes DD, PS2 which are now referred to D and P respectively in column 26. IND also includes R, H, D of column 26.

col 26 -- symmetry code. The allowable symmetry codes are: S M Z E 3 P R H D. These are described in Chapter 6.2. This field is left blank at a given depth if the next symmetry code down the column applies to the given depth (see example on the following page).

col 28-32 -- observation for the S_0 plane as follows:
col 28-29 angle to the core axis (0-90)
col 30-32 dip-direction (0-360) with respect to S_1 using the right hand rule (see Fig. 6.3.1).

col 34-38 -- observation for the S_1 plane as follows:
col 34-35 angle to the core axis (0-90)
col 36-38 dip-direction (0-360). Where S_1 is the reference fabric element the azimuth is inserted once at the top of the field sheet or where the azimuth changes. Where S_2 is the reference fabric element, the dip-direction of S_1 is measured using the right-hand rule with respect to S_2 , which is the reference fabric element.

col 40-44 -- observation for the S_2 plane as follows:
col 40-41 angle to the core axis (0-90)
col 42-44 dip-direction (0-360). Where S_2 is the reference fabric element the azimuth is inserted once at the top of the field sheet or where the azimuth changes.

An example of the field sheet used to record structural observations is contained on the following page.

DDH E.G. 78 C 06
2 8

Cyprus Anvil Mining Corp.

Structural Log

Date: July 1978 Logged By: DK, WR

Code	From		To		Feature	S ₀ Dip Direct.	S ₁ Dip Direct.	S ₂ Dip Direct.	Description			
	10	14	16	20						22	24	26
				323					Casing			
S				366		40 000	36 210		⊙ S ₁			
S				475		42 000	38		S ₁ +S ₀			
S				643		40 000	34					
S				667		40 000	37					
S				698		43 000	36					
S				710	F1	45 180	40		Short "s" limb of Z minor fold			
S				719		45 270	35		⊕ S ₀			
S				730		45 000	42		S ₁			
S				744	Z				end of Z-symmetry zone			
S				750	S	32 000	35					
S				756	R		36		S ₀ not visible; highly cleaved			
S				765	Z	43 000	30					
S				768		28 000	35					
S				777	S				end of S-symmetry zone			
S				789			50		S ₀ not visible			
S				805			44		"			
S				821			48		"			
S				832			36		"			
S				843	R							
S				849		45 330	55					
S				875		40 000	45					
S				884		40 000	50					
S				896		25 040	55		S ₀ ⊕ S ₁			
S				904	S							
S				905		68 000	63					
S				936		40 240	50					
S				954	Z	55 020	40					
S				962		45 000	55					
S				984		40 325	50					
S				1009		46 000	53					
S				1021		48 335	50					
S				1027	S							
S				1033			55					
S				1042			55					
S				1058	R		53					

6.2 Symmetry Codes

We have arbitrarily divided structural observations into two types:

6.2.1 Zone Observations

6.2.2 Point Observations

Zone observations refer to the region within the core sequence (example - a zone of S - symmetry) above the plotted symbol and below the previous symbol in column 26. The zone ends at the mid-point of the symbol. Point observations are for single locations (example - measurement of S_1 and S_2 relative to the core axis) at the plotted symbol.

6.2.1 Zone Observations:

The different symbols (and observations) under this heading are:

S, Z, M, P, R, H, D.

- (1) S and Z refer to zones of S or Z-symmetry.
- (2) M refers to a zone of mixed symmetry. Typical examples include large hinge zones or short, steep limbs. Use of this symbol allows for uncertainty in locating symmetry changes over large zones.
- (3) P is a specific term referring to a pervasive fabric element such as pressure-solution striping or pervasive schistosity such that symmetry cannot be determined. Three criteria should be used to recognize this:
 - (a) It is present in more than one rock type.
 - (b) Microlithon structures are not visible.
 - (c) Ideally there should be a transition from a crenulation cleavage to a closely spaced crenulation cleavage to a pervasive schistosity.

- (4) R is a more general term (like garbage term) for regions without microlithon textures which cannot be definitely related to pervasive textures. It would include regions of transposed S_1 or S_0 . Similarly, it would include regions where rocks do not contain microlithon textures (like Anvil massive 5D or 5C or totally re-crystallized 5A, 3E, etc.). In the Gataga District, R is used where S_0 and S_1 cannot be distinguished, hence appear to be parallel. In summary, R is intended to be used for rock-type controlled, fabric domains where criteria for P have not been met and symmetry cannot be determined.
- (5) H refers to a zone which has the reference fabric element perpendicular or parallel to the core axis so that symmetry cannot be determined. The symbol H was originally chosen for the Anvil District where S_2 is horizontal and drill-hole vertical. Two other cases of this problem occurred on the Elf where a vertical drill-hole intersected vertical S_1 and a nearly horizontal drill-hole intersected vertical S_1 .
- (6) D refers to a zone in which the dip azimuth of the reference fabric element is perpendicular to that of the other fabric element(s) because the core axis is (1) oriented down the plunge of a fold or (2) oriented with an azimuth close to the strike of the reference fabric element.

6.2.2 Point Observations:

The different point observations are:

E and 3

F 0/1/2/3/4/5....

S 0/1/2/3/4/5....

Faults

The symbols E and 3 are used for actually observed fold closures in the style indicated by the shape of the symbols. The E and 3 symbols also have the function of zone observations and indicate a reversal of symmetry: for E the zone above the symbol has implied S-symmetry and the zone below has Z-symmetry; for 3 the overlying zone has implied Z-symmetry and the underlying zone has S-symmetry.

F 0/1/2/3/4/5...n is the point observation of a fold related to the appropriate deformation D 0/1/2/3/4/5...n. F 0/1/2/3/4/5... is recorded in the Feature column. Regions for this observation may be specified in the Description column by listing a footage range for the fold pattern. This observation is intended only for locally observed fold patterns. Measurements of these folds may be recorded by measuring:

- (1) Angle between dip directions for the axial plane of the fold and the reference fabric element.
- (2) Angle of observed fold axis with the core axis.
- (3) In the case of sedimentary folds, F_0 , the direction of overturning of the fold when way-up is known.

S 0/1/2/3/4/5 is a point observation of the orientation of a particular planar element. In most cases in Dy and Vangorda deposits this observation will be the S_2 foliation. In the Gataga District S_0 (bedding) and S_1 (cleavage) are measured. Measurements of S_3 , S_4 , S_5 structures must presently be handled in the same manner as above for the F 0/1/2/3/4/5 fold elements.

Point observations are at the locations indicated by the tic mark on the plotted structure log.

Faults are recorded in the lithology log, as indicated in the Appendices. Particular attention should be paid to fault attitudes. These attitudes should be recorded in the structure log in the "Description" column relative to the reference fabric element.

Examples

Examples of the computer printouts for the S_0 and S_1 planes at 1:1000 scale are on the following pages. Please note that this is probably the maximum density of data that can be plotted legibly. Additional readings can be recorded and then selectively plotted by recording § instead of the "S" code in column 1.

The ideal distance between "S" coded readings at 1:1000 is about 3 meters. The § data could be later retrieved for plots at expanded scales.

[]H:EG78C-06

-- 50 DEGREE PROFILE
(VIEW AZIMUTH = 320 DEGREES)

ELEV. 1635 370833 E, 6375536 N

DDH - METRES
0.0

ELEVATIONS
BENCH

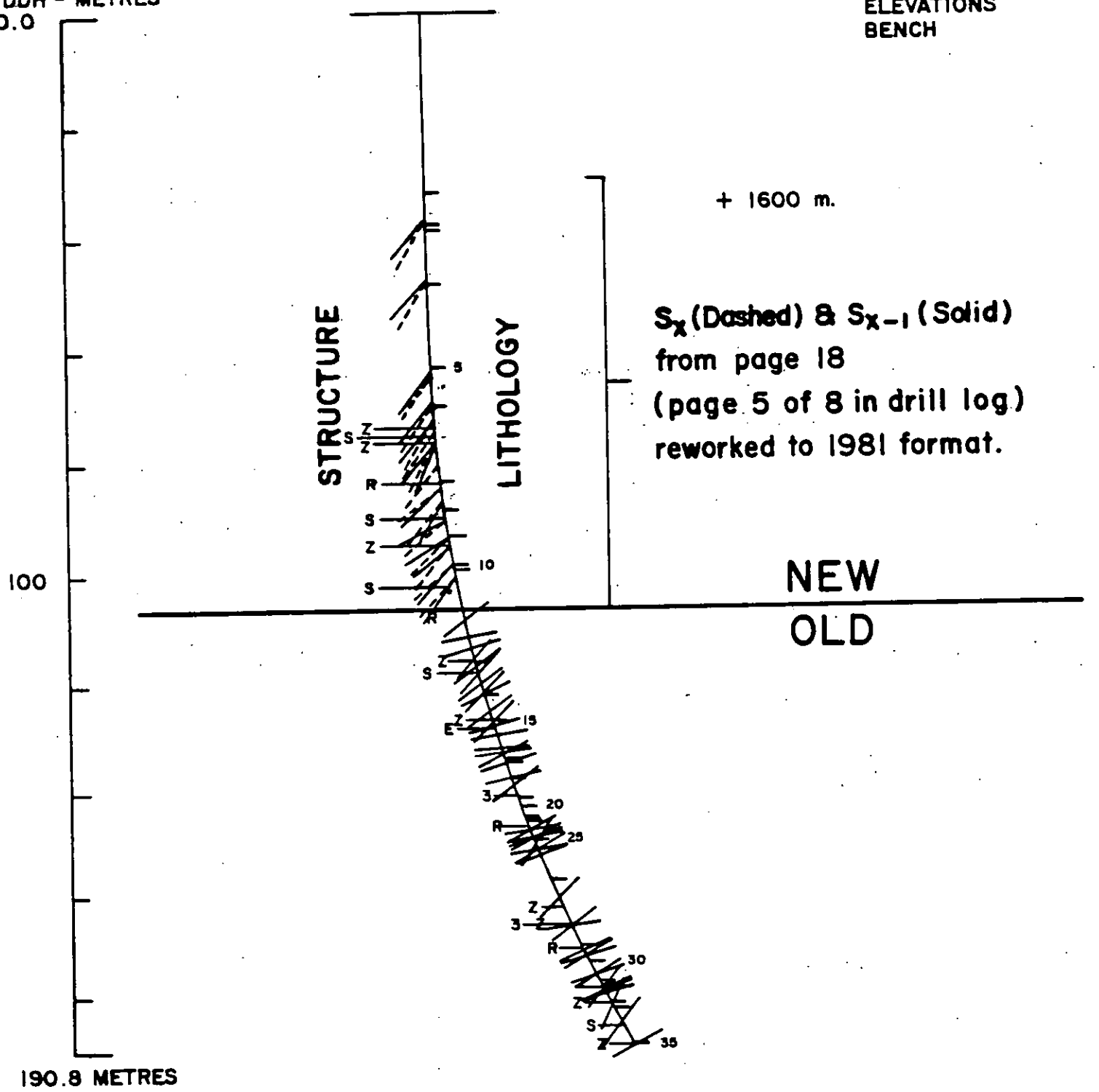

6.2.3 Sample computer plot of S_0 at 1:1000, 1980 (old) format. Top 1/2 S_x & S_{x-1} in 1981 format, data listed on page 17.

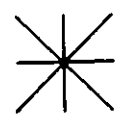

CYPRUS ANVIL MINING CORPORATION
PROGRAM DDH PLT 01/31/80 10:58:41
PL0TD, 1000, 050,, B

PLOTS FINISHED

DDH:EG78C06

-- 50 DEGREE PROFILE
(VIEW AZIMUTH = 320 DEGREES)

ELEV: 1635 370833 E ; 6375536 N

DDH- METERS
0.0

ELEVATIONS
BENCH

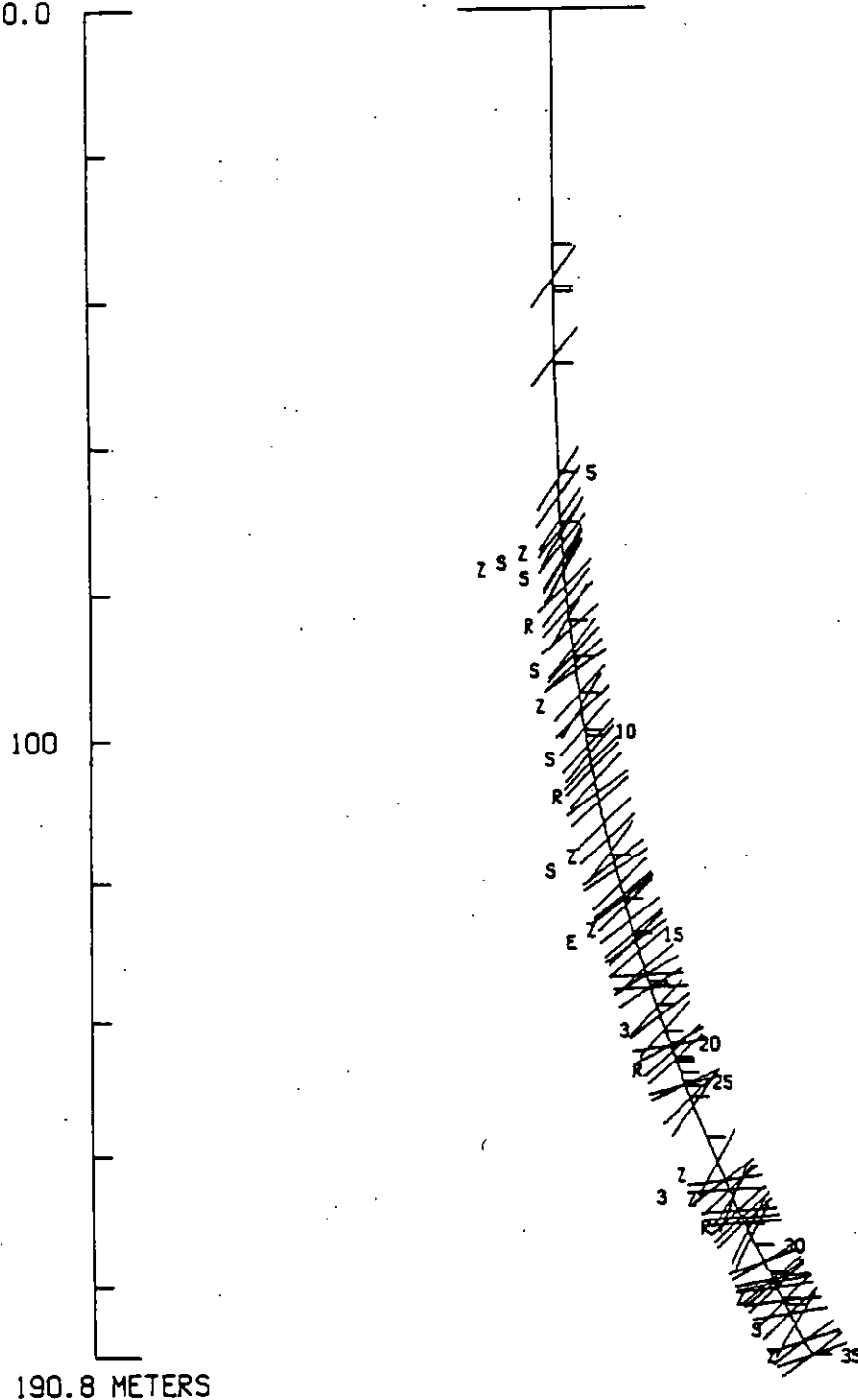

6.2.4 Sample computer plot of S₁ at 1:1000, some data listed on page 17. 1980 format

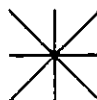

6.3 Structural Synthesis (or antithesis)

Structural synthesis is based on the determination of (1) dip line azimuths and their use in defining (2) symmetry: the relationship between the reference fabric element and other fabric elements in the structural section.

6.3.1 Dip Line Azimuths and the Right Hand Rule

The dip line azimuth is the azimuth of the direction of maximum dip of a fabric element. It is determined locally for each drill area. Surface observations of fabric elements are averaged to provide a mean strike and dip for the reference fabric element in the drill area. Orientation of other fabric elements in drill core is determined with respect to the reference fabric element, assuming a constant dip direction for that element. The following method is new in 1981 and replaces the previous method explained in Appendix I.

Step 1

The first step involves recognition of the fabric elements, something that can only be done with some field experience.

Step 2

The second step involves removing the core from the core box and orienting it in the original position before it was drilled. To do this the core is held in approximately the position of the drill-hole, making sure it is right-side up.

Step 3

The lowest points on the planes representing the fabric elements are identified and marked on the sides of the core, then projected to the top end of the core where the angular distance can be measured (Figure 6.3.1).

Step 4

The angular distance from the lowest point on the plane of the reference fabric element to the lowest point on the plane of other fabric element is measured in a clockwise direction looking in the direction of drilling. This is easily remembered using the RIGHT HAND RULE in which the right hand is held with the thumb pointing in the drilling direction, parallel to the axis of the core and the fingers of the right hand are grasping the core (Figure 6.3.1). The direction in which the fingers point is the direction of measurement of the angular distance from the reference low point to the other low point. This angular distance can be measured on the back end of the core using a protractor. Grasping the core with the left hand, with thumb pointing up the hole, allows fingers to point in the same direction, giving identical results.

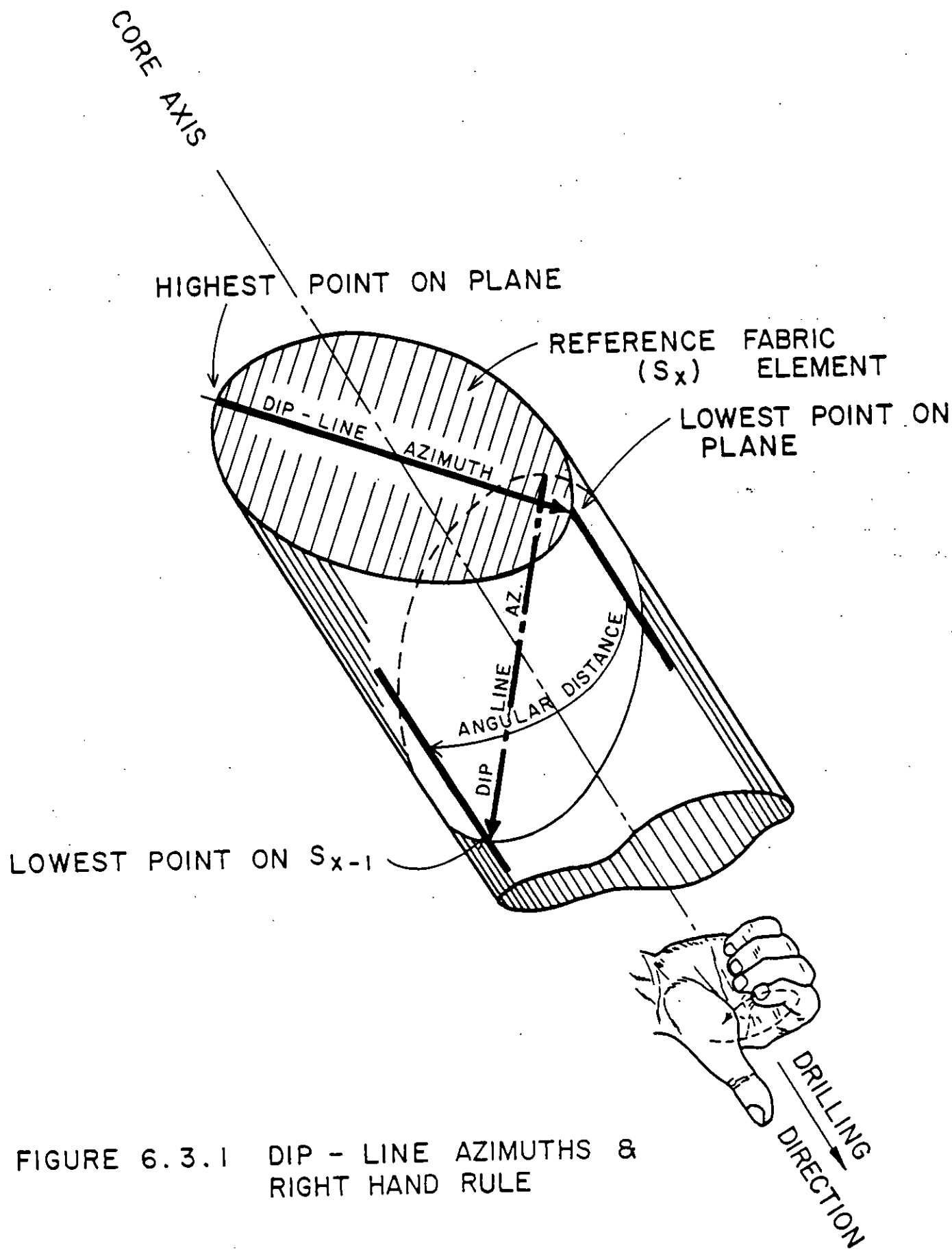

FIGURE 6.3.1 DIP - LINE AZIMUTHS & RIGHT HAND RULE

6.3.1.1 Example 1 (Cirque):

Only one main phase of folding has been observed in the vicinity of the Cirque. S_1 (axial planar cleavage) is relatively constant within the immediate vicinity of the deposit; S_1 strikes at about 120° , dips southwest at about 50° to 80° . In all of the structural syntheses for the Cirque drill holes, S_1 is therefore assigned a dip azimuth of 210° . S_1 is recorded as the R.F.E. in the top right corner of page CAMC1981-E-2, and dip azimuth of S_1 is recorded once at the top of each page CAMC1981-E-4 in columns 36-38 (see example, page 18).

In figure 6.3.1.1 on the following page, the core on the left is illustrated as lying in the core box. On the right the core has been picked up and placed in the drilling position as determined by Sperry Sun or gyro tests; the core has been rotated about its axis so that S_1 dips SW. This helps to visualize the structure, although it is not necessary just for measuring S_1 and S_0 .

The fabric elements are measured with respect to only the core and each other. Using a protractor or contact goniometer the maximum angle of S_1 to the core axis is measured to be 50° . The maximum angle of S_0 (bedding) is 80° . It is also noted that with respect to the core axis, S_0 dips opposite to S_1 . Another way to express this is that the lowest point on S_0 is 180° away from the lowest point on S_1 .

6.3.1.2 Example 2 (Cirque):

The above example is one in which S_0 and S_1 have the same strike and the drill core intersects the strata at an azimuth which is at right angles to this strike. If S_0 and S_1 have different strikes (plunging folds) or if the drill hole intersects the strata at an azimuth oblique to the strike (very common at Cirque), then the determination of dip line azimuths becomes more complex. The following example is a relatively simple one with drill core vertical. There are three steps of measurement:

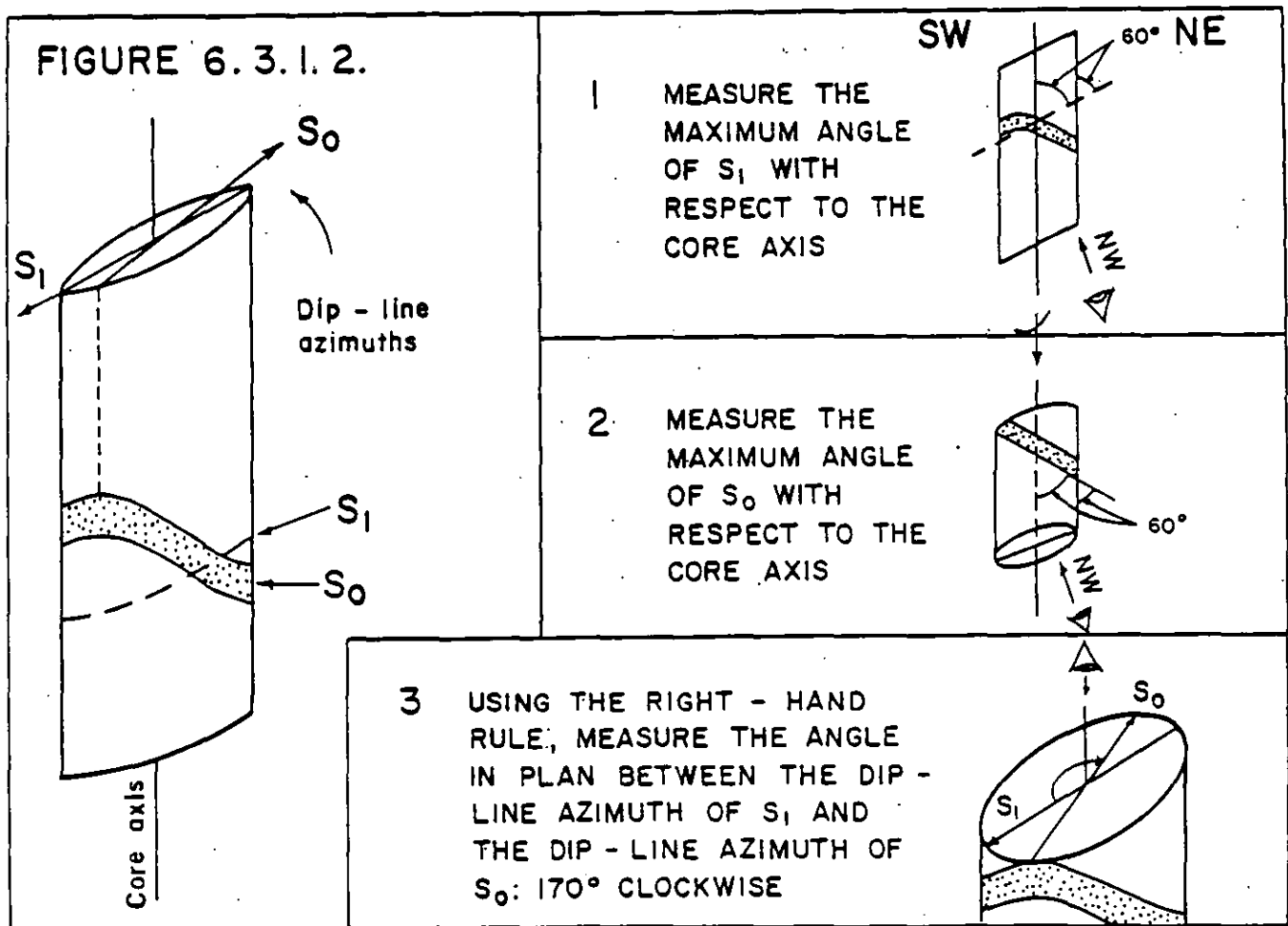

The results of these measurements would be recorded as follows:

Code	From	To	Feature	S_1	S_0	S_2	Description
	10	14 16	20 22 24 26 28	29	32 34	38 40 44	
S		2,1,0	4	Z	6,0 1,7,0	6,0 2,1,0	

In this example it is critical to know that the core is right-side up, otherwise the S_0 direction could be 190° .

6.3.1.3 Example 3 (Cirque)

In this example, poker chip shale, the core happens to break along S_0 . If S_0 and S_1 have the same dip azimuth but different angle of dip:

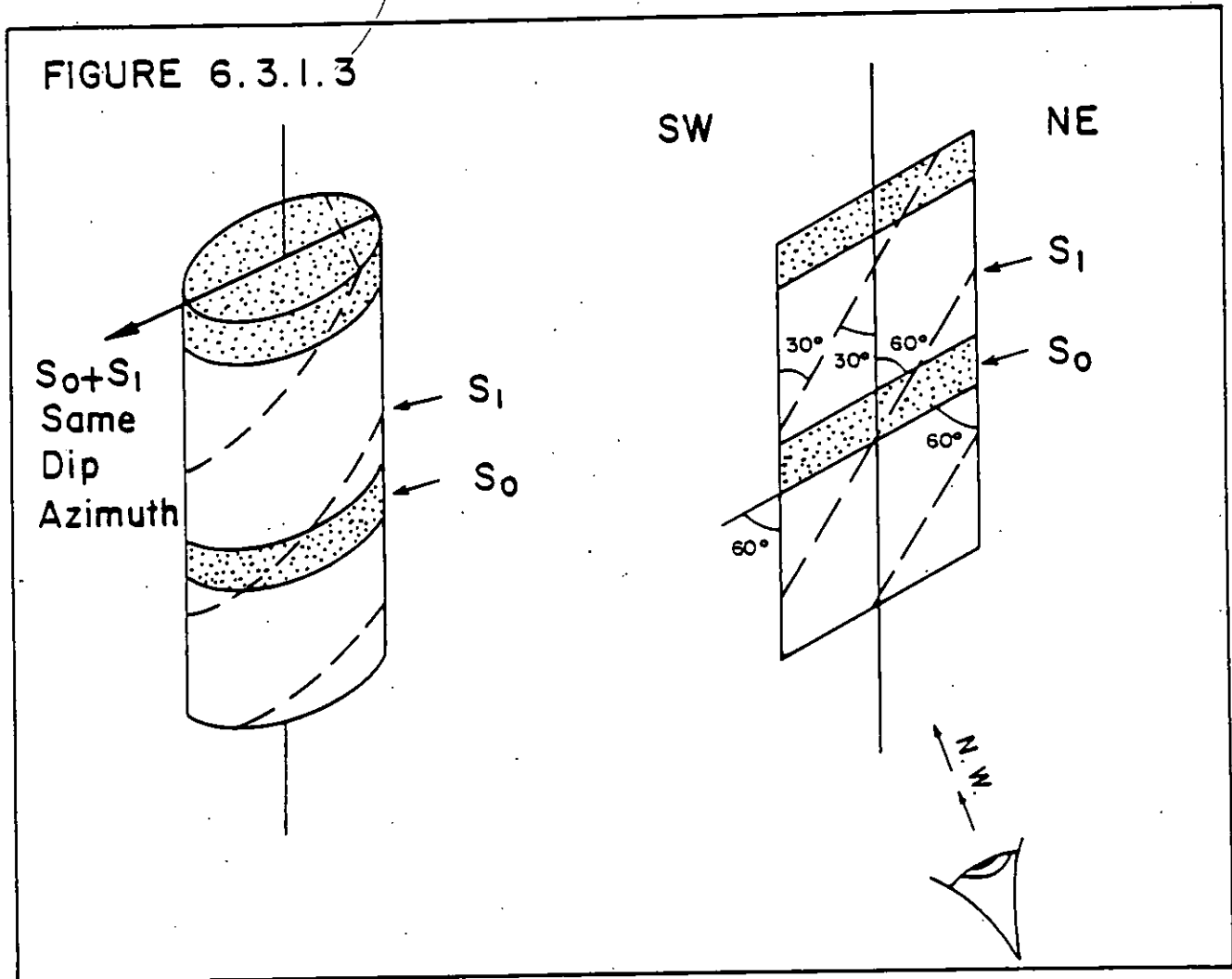

This would be recorded as:

Core	From		To		Feature	# of	S_0		S_1		S_2		Description
	10	14	18	20			Dip	Direct.	Dip	Direct.	Dip	Direct.	
S			2,3	4	Z		60	0,0	30	2,1	0		

6.3.1.4 Example 4 (Anvil District)

The same procedures as above are followed, except that S_2 is the reference fabric element and S_1 plays the role that S_0 did in Gataga. S_0 and S_1 are mainly transposed or were originally very close to S_2 . S_0 is mainly preserved as microlithon structure (rock material between cleavage planes that is folded or kinked) in the plane of S_1 . The microlithon structure and S_1 are folded and kinked with axial plane S_2 . S_2 has a very gentle dip towards an azimuth of 185° but in about 30% of the area dips gently north. Therefore symmetry is often difficult to determine.

The following figure shows a case in which there are two possible orientations of the core. This is because there is a high angle between the sub-horizontal reference fabric element (S_2) and the near-vertical drill core axis. Both S_1 and S_2 dip toward 185° , no matter how the core is oriented.

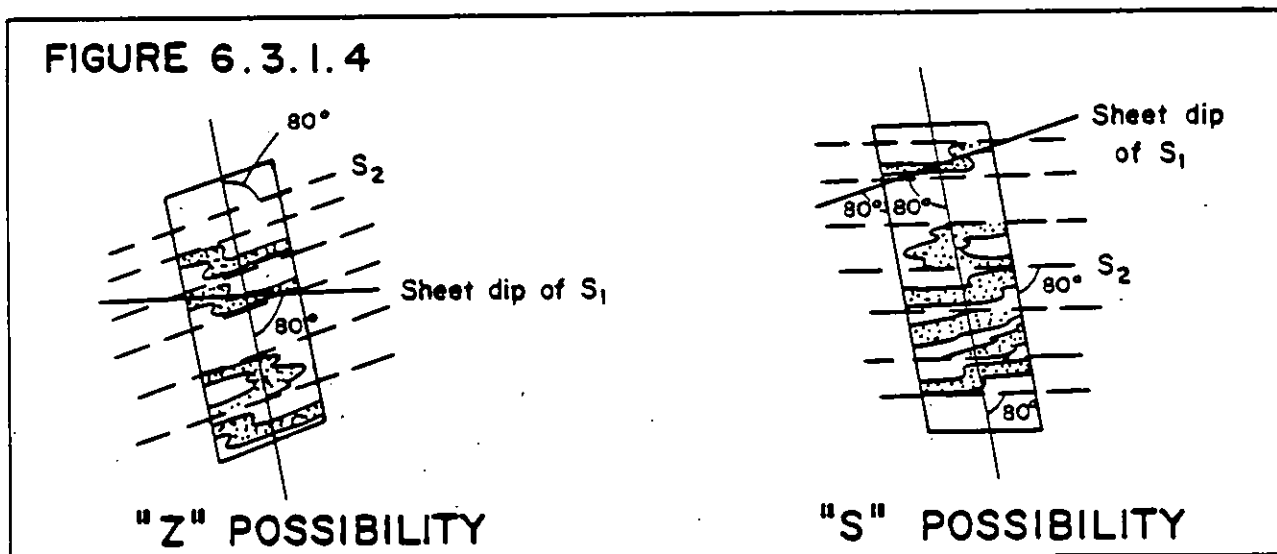

B.V.H. from previous experience and looking at core above thinks the structure is Z. The dip azimuths of S_1 and S_2 are opposite (180°). This would therefore be recorded as:

Core #	From		To		Feature #	S_0 Dip Direct.		S_1 Dip Direct.		S_2 Dip Direct.		Description	
	10	14	18	20		22	24	26	28	32	34		38
S			5,000		Z			80	1,80	80	1,85		

and plotted as:

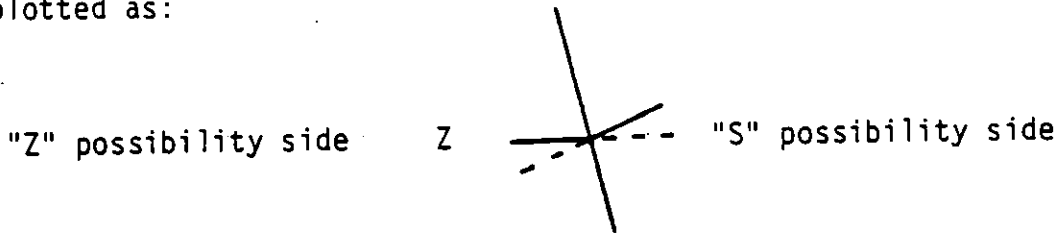

Both options must be plotted because the R.F.E. dips nearly horizontally no matter how the core is oriented. But Z plotted beside the ticks reminds B.V.H. what he thought was the solution in the field.

6.3.2 Symmetry Determination

In the Gataga District the convention for determining symmetry of folds is to look northerly at the structure. Thus on page 1 of the Cirque drill log:

All symmetry determinations looking:

NW with S_1 dipping

SW with dip azimuth 210°

Most fold structures in the Gataga District are first phase, tight to isoclinal; inclined to overturned, verging to the Northeast, so that the standard fold pattern is:

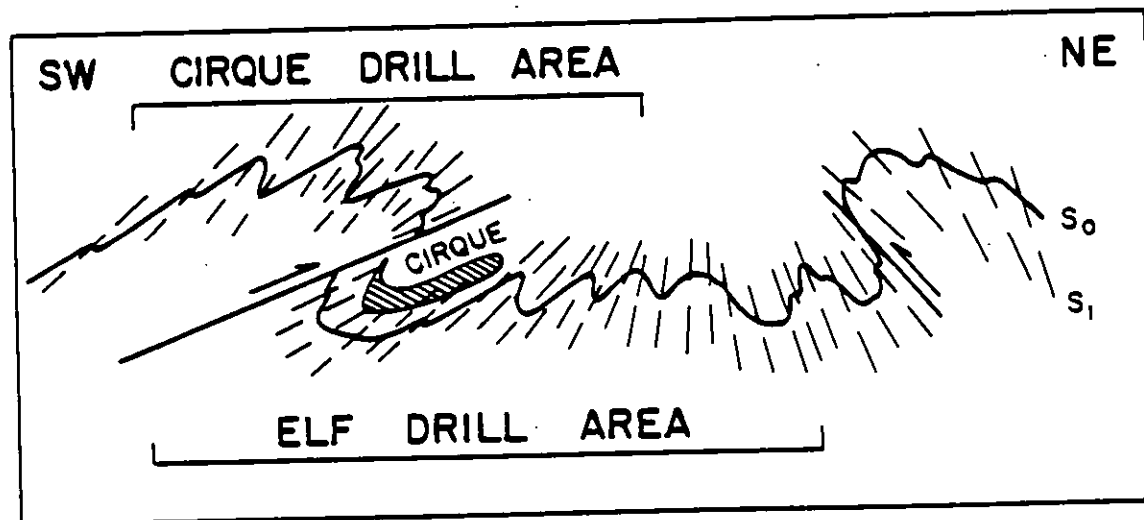

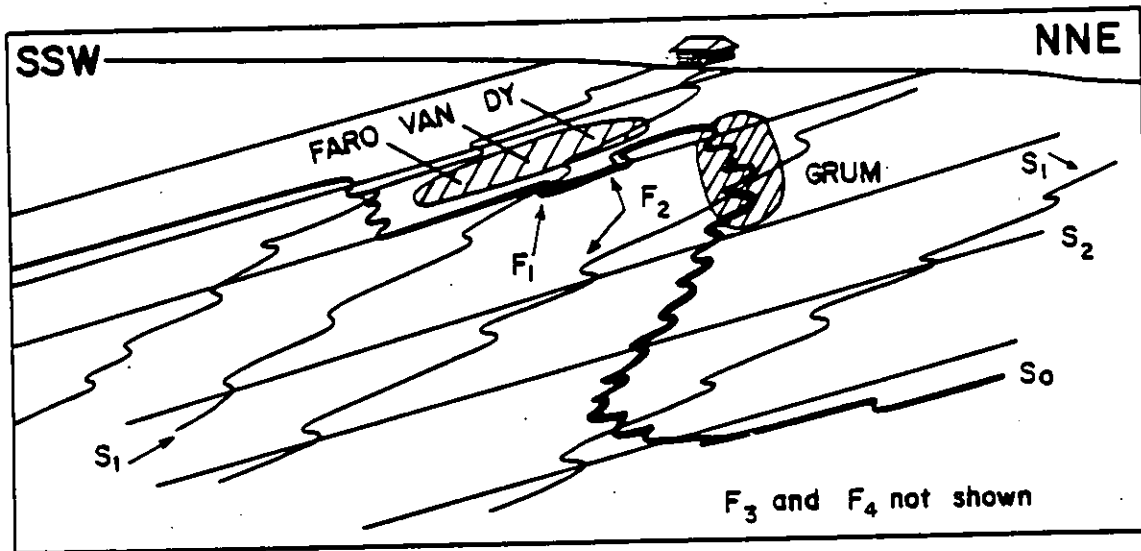

In the Anvil District the deposits are mainly on the "Z" limb of a large-scale first-phase anticline. F_2 has had the effect of pervasively flattening the first-phase structures, with S_2 being close in orientation to S_0 and S_1 . The generalized fold pattern (for explanation see D.S.J.) looking WNW is:

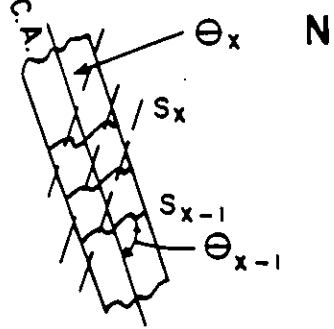
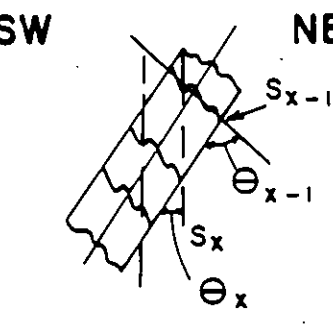
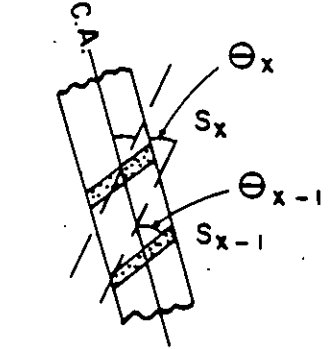
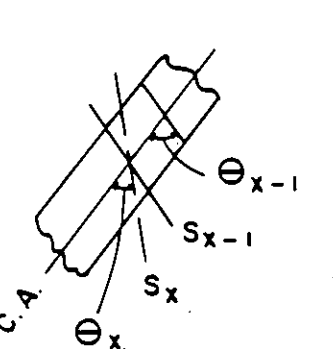
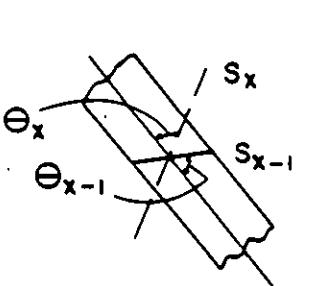
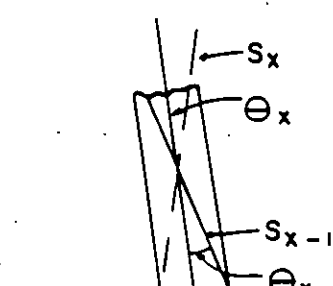
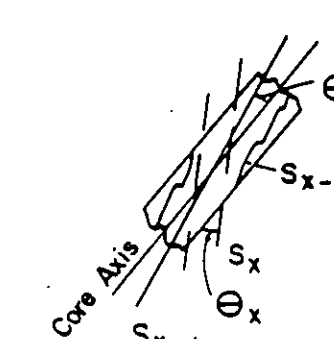
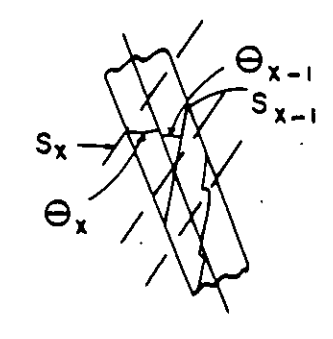

6.3.2.1 Examples of Symmetries in core:

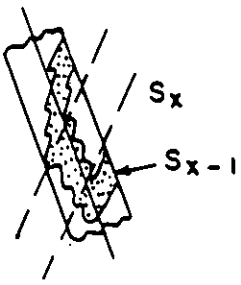
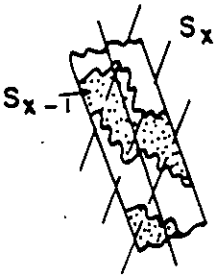
Fabric Elements	"Z" Symmetry	"S" Symmetry
<p>$\Theta_{x-1} > \Theta_x$ with minor folds Same dip azimuth dir.</p>		
<p>$\Theta_{x-1} > \Theta_x$ Same dip azimuth dir.</p>		
<p>$\Theta_{x-1} = \Theta_x$ Opposite dip azimuth directions</p>		
<p>$\Theta_{x-1} < \Theta_x$ Same dip azimuth dir.</p>		

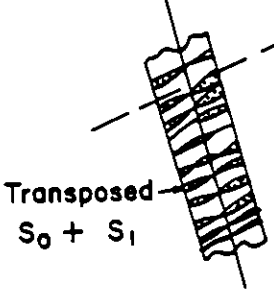
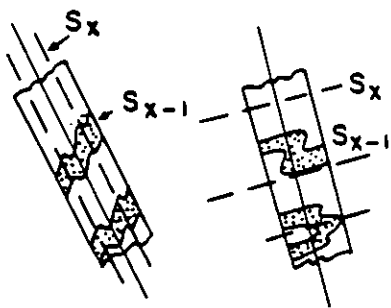
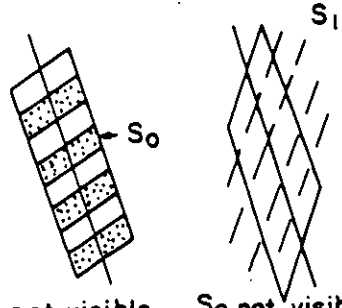
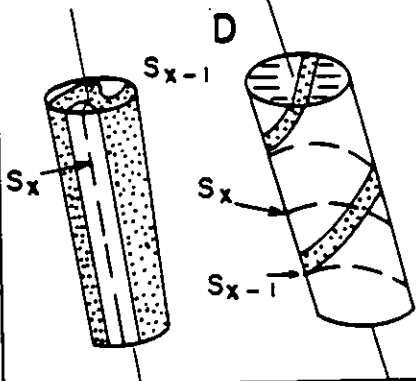
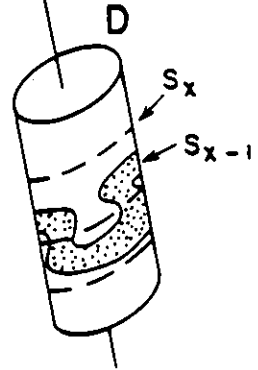
Fabric Elements	Symmetry Examples	Symmetry Examples
<p>S_x; minor folds in S_{x-1}</p>	<p>SW "E" NE</p> 	<p>SW M NE</p> 
<p>S_x; minor folds in S_{x-1}</p>	<p>"3"</p> 	<p>R</p>  <p>Transposed $S_0 + S_1$</p>
<p>S_x, S_{x-1}</p>	<p>H</p> 	<p>R</p>  <p>S_1 not visible S_0 not visible</p>
<p>Dip azimuth direction $S_x \perp$ dip azimuth direction S_{x-1}</p>	<p>D</p> 	<p>D</p> 

6.3.2.2 Example of Structural Synthesis:

DDH EXAMPLE
2 8

Cyprus Anvil Mining Corp.

Page _____ of _____

Structural Log

Date: 1980 Logged By: LCP

Code	From		To		Feature	S ₀ Dip Direct.	S ₁ Dip Direct.		S ₂ Dip Direct.		Description	
	10	14	16	20			22	24	28	32		34
S				100	S ₂							
S				200	S ₂							
S				300	S ₂							
S				400								
S				500								
S				600								
S				700								
S				800								
S				900								
S				1000	S ₂ R							

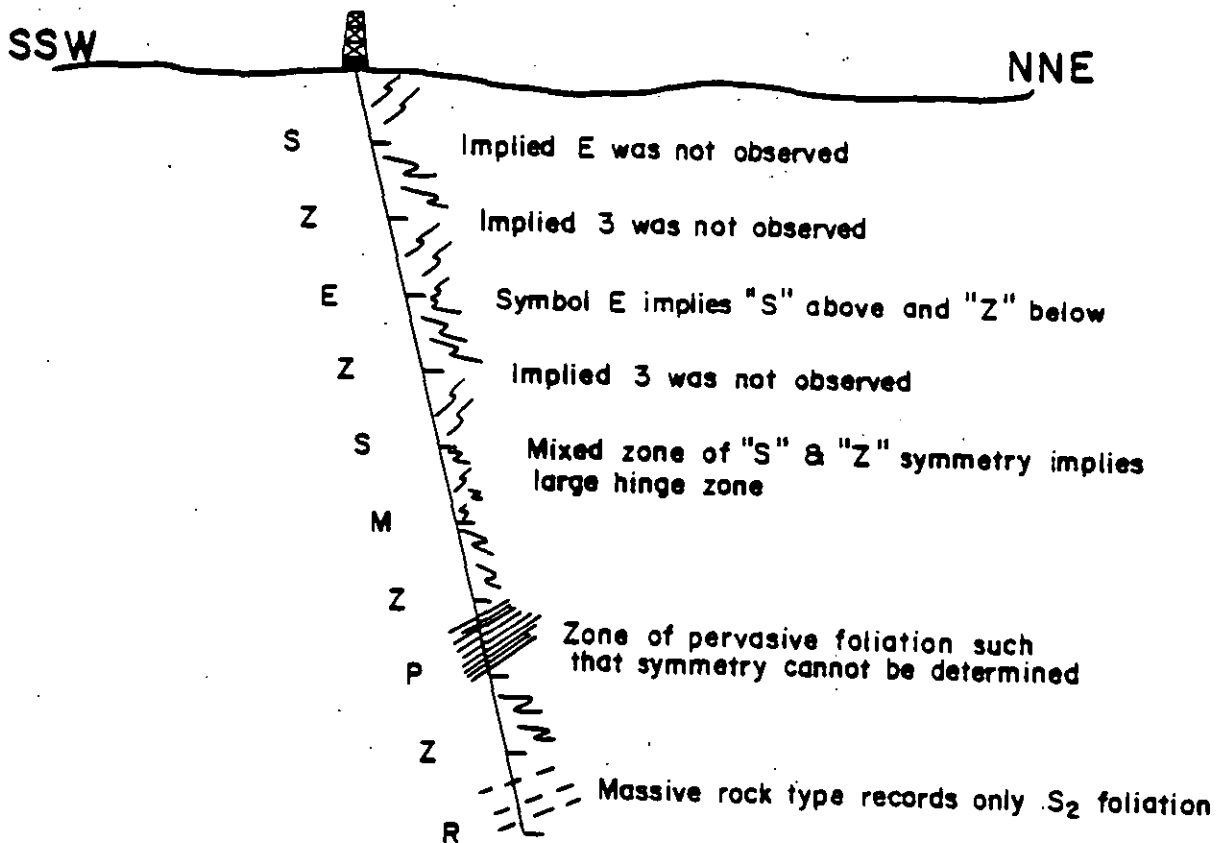

7. PAGE CAMC1981-E-5 OF LOGS: ASSAY SAMPLES

7.1 Type "P" Data Card - Assay Log (Sample Location)

This data card is used to record the depth and sample number of specimens from the drill core that have been taken for assay. The sample is always taken over an interval denoted by the from-depth and the to-depth; however, for processing a point depth equal to the mid-point of the interval is used. The format of the data card is shown below:

- col 1 -- card code "P"
- col 2-8 -- drill-hole identifier which must be the same as used on the header card (type "T") for this drill-hole
- col 10-14 -- from depth. This depth is recorded in units of 0.1 feet (or meters) with the decimal point assumed between columns 13 and 14.
- col 16-20 -- to-depth. This depth is recorded in units of 0.1 feet (or meters) with the decimal point assumed between columns 19 and 20. Both the from-depth and the to-depth must be present. The actual location of the sample is taken to be at the midpoint of the sample interval.
- col 22-26 -- sample number of the specimen sent for assaying. The assay results are recorded on a separate data card. The sample number is an integer value only. Steps have been taken to assure unique numbers for each property (see J.G.S.).
- col 28-30 -- Sample interval (i.e. difference between FROM and TO depths). This is recorded in units of 0.1 meters (or feet) with the decimal point assumed between columns 29 and 30
- col 32-34 -- recovered length of sample. This is recorded in units of 0.1 meters or feet with the decimal point assumed between columns 33 and 34.
- col 36-40 -- lithostratigraphic code of the sample material (see chapter 5; appendices II, III).

RESEARCH SAMPLE LOG

PROJECT: _____

UNIT: _____

STATION: _____

ROCK NAME: _____

DDH: _____

DEPTH: _____

HAND SAMPLE:

THIN SECTION:

POLISHED SECTION:

POLISHED THIN SECTION:

ANALYSIS:

PROBE:

XRD:

ISOTOPE:

FOSSIL:

STAINED:

OTHER:

COMMENTS:

REFERENCES

- Laing, W.P. 1977. Structural interpretation of drill core from folded and cleaved rocks. *Economic Geology* 72, 671-685.
- Marlon-Lambert, J.R. 1980. Drill-Hole Data Handling System - General System Notes. Cyprus Anvil Mining Corporation, July 15, 1980.

APPENDIX I

GRANDFATHERED METHOD OF MEASURING STRUCTURAL ELEMENTS IN DRILL CORE

Prior to 1981, structural fabric elements were measured in core on an absolute rather than relative basis and the directions recorded in the structural log were all best attempts at true azimuths.

The attitudes of the reference fabric element (S_x) and related fabric elements (S_{x-1}) in core were determined by first orienting the core so that the axis of the core was in the direction it was drilled and S_x dipped to the Southwest. Then the maximum dip angle of S_x and S_{x-1} with respect to the core axis were measured. Finally the dip direction of S_{x-1} was measured as an azimuth with respect to the plane of the horizontal.

The following four examples have the same fabric element geometries as the examples in the text so that the different methods of treating the same data can be compared.

Grandfathered Example 1 (Cirque)

Refer to Example 1 in the text. Before 1981, S_1 (axial planar cleavage) was thought to strike at about 140° , and dip southwest at about 50° . In all of the structural syntheses for the Cirque drill holes, S_1 was therefore assigned a dip azimuth of 230° . Before 1981, correct orientation of the core as shown was crucial for measuring S_0 .

In the following figure the dip of S_0 was exactly opposite to that of S_1 with respect to the core axis but in true space both had a dip azimuth of approximately 230° .

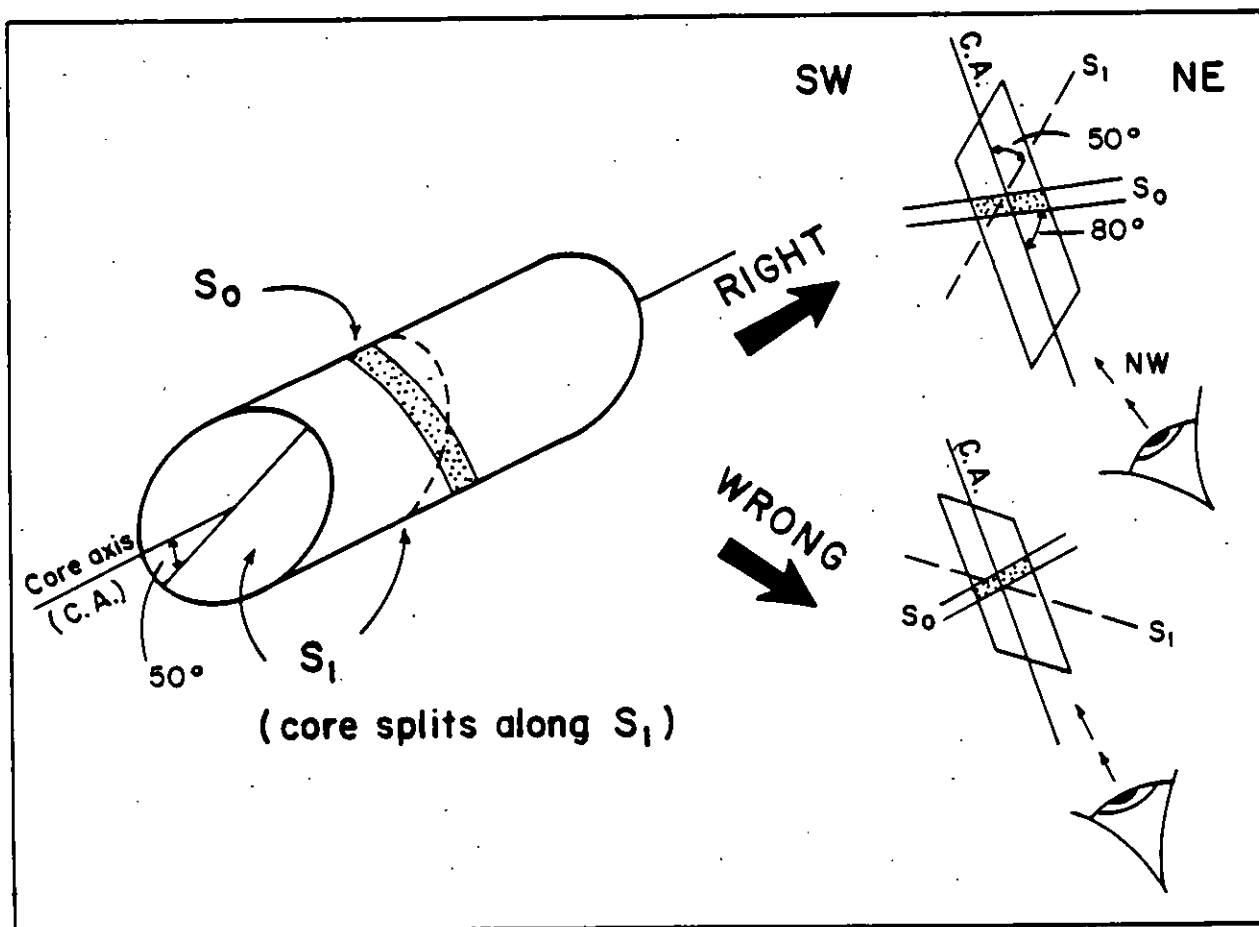

In the structural log these were recorded:

Code	From	To	Feature	S_1 Dip Direct.	S_2 Dip Direct.	Bedding S_0 Dip Direct.
1	10	14 16	20 22 24 26 28	32 34	38	40 44
S		1360	Z	50 210		80 210

or:

S		1360	Z	50 210		80 030
---	--	------	---	--------	--	--------

depending on how accurately the core was oriented when measured.

S_1 was plotted:



S_0 was plotted:



and there was no way of telling which was correct without referring to the log.

Also, in some cases the person doing the logging thought that in real space S_0 was dipping towards 050° . But when the computer plotted the hole, it turned out that the 050° azimuth was impossible: S_0 was actually dipping very shallowly to the southwest. In this instance the computer bombed out and plotted S_0 as a dashed line perpendicular to the drill hole.



Grandmothered Example 2 (Cirque)

The above example was one in which S_0 and S_1 had the same strike and the drill core intersected the strata at an azimuth which was at right angles to the strike. If S_0 and S_1 had different strikes (plunging folds) or if the drill hole intersected the strata at an azimuth oblique to the strike (very common at Cirque), then the determination of dip line azimuths was more complex. The following example was a relatively simple one with drill core vertical. There were three steps of measurements:

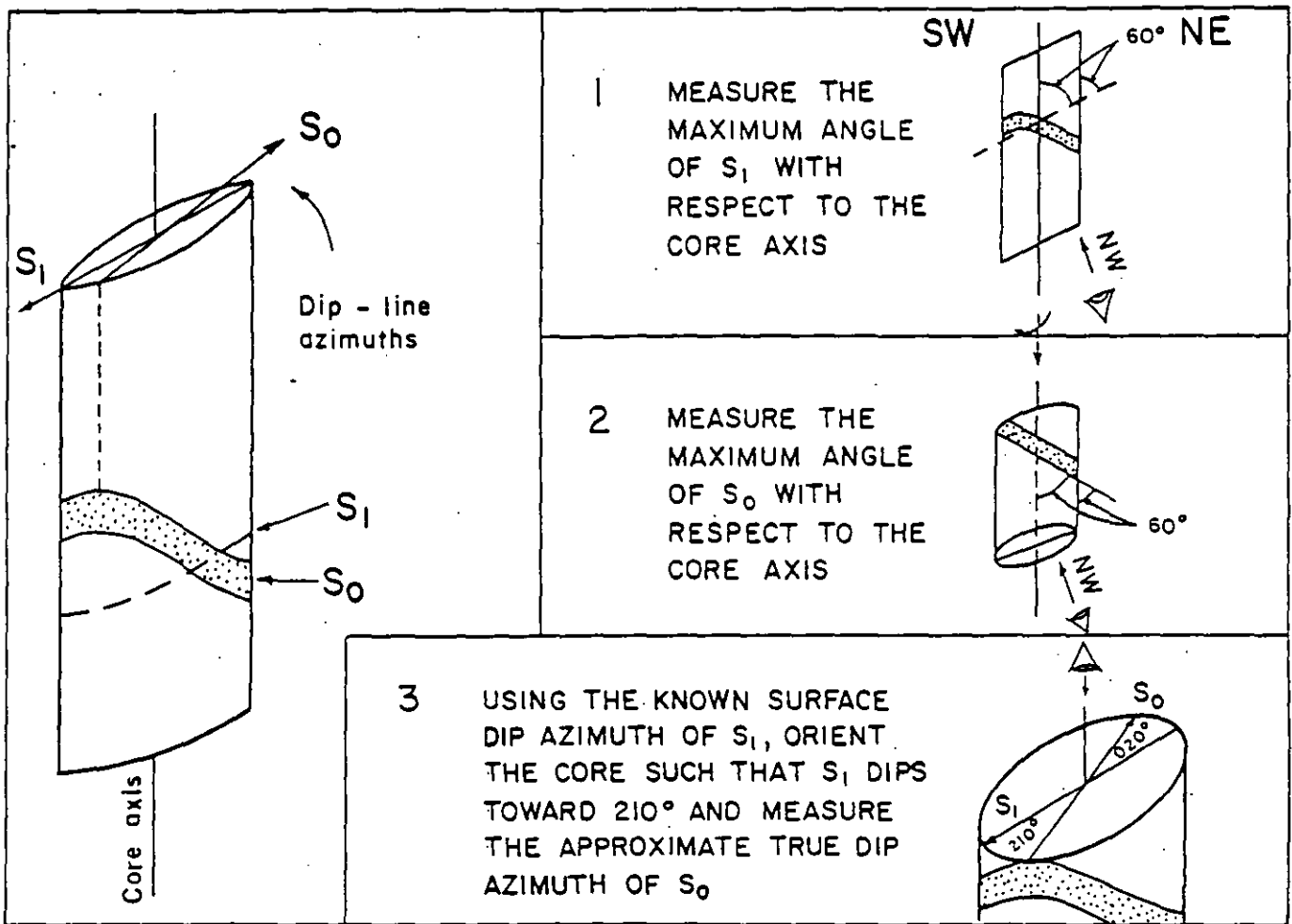

The results of these measurements were logged as follows:

Core	From	To	Feature	S_1 Dip Direct.	S_2 Dip Direct.	Bedding S_0 Dip Direct.
1	10	14 16	20 22 24 26 28	32 34	38 40	44
S		2, 3, 0, 4		2, 6, 0, 2, 1, 0		6, 0, 0, 2, 0

In this example it was critical that the core was right-side up or S_0 would have been assigned a dip azimuth of 040°.

Ancient Example 3 (Cirque)

If S_0 and S_1 had the same dip azimuth but different angles of dip:

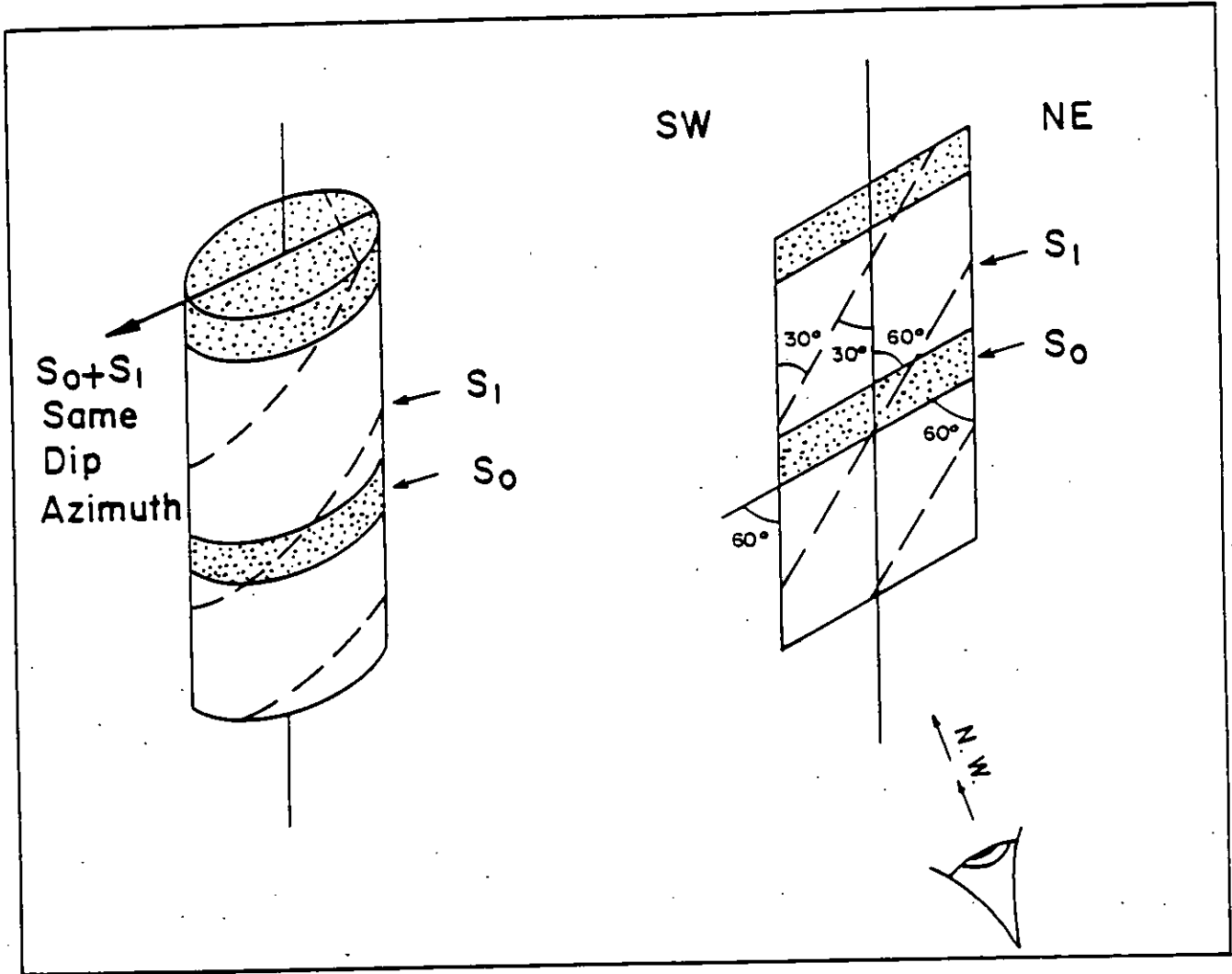

This was recorded as:

Code	From	To	Feature	S ₁ Dip Direct.	S ₂ Dip Direct.	Bedding S ₀ Dip Direct.
1	10	14 16	20 22 24 26 28	32 34	38	40 44
S		2,3,0 4		Z 5,0 2,3,0		8,0 2,3,0

Although this example was very different from example 1, the recorded data and print-out in 1980 of examples 1 and 3 were indistinguishable.

Great-Grandfathered Example 4 (Anvil District)

The same procedures as above were followed, except that S_2 was (and still is) the reference fabric element (R.F.E.) and S_1 played the role that S_0 did in Gataga. S_0 and S_1 are mainly transposed or were originally very close to S_2 . S_0 is mainly preserved as microlithon structure (rock material between cleavage planes that is folded or kinked) in the plane of S_1 . The microlithon structure and S_1 are folded and kinked with axial plane S_2 . S_2 has a very gentle dip towards an azimuth of 185° but in about 30% of the area dips gently north. As in the text examples 6.3.1.4 the following figure shows two possible symmetries.

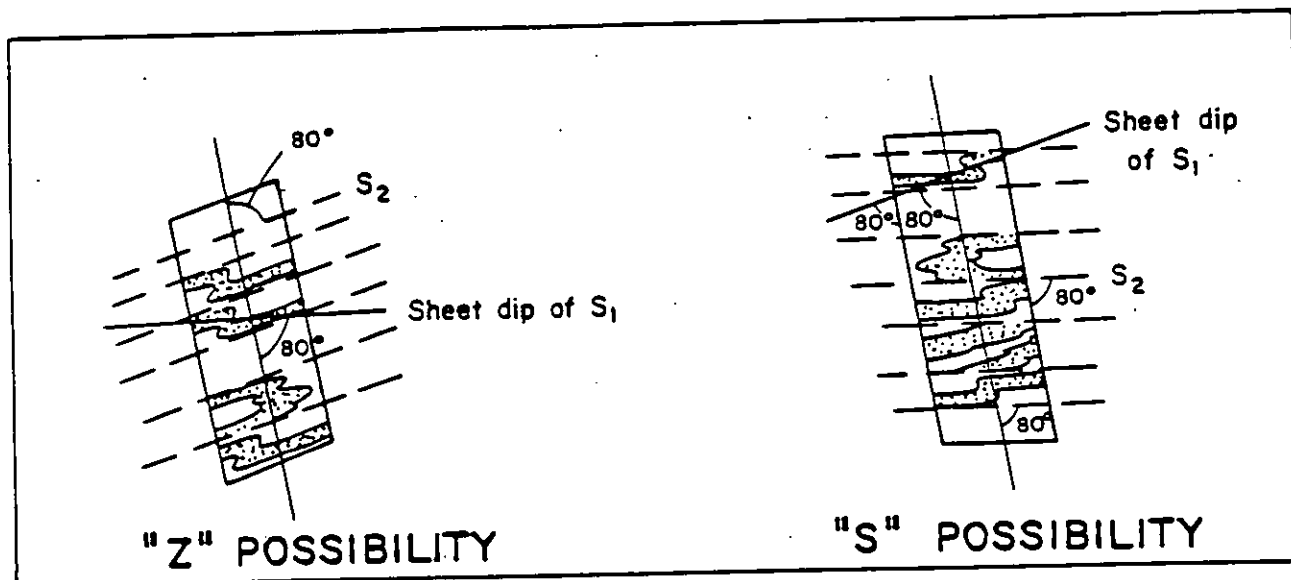

Note that because S_2 and S_1 cut the core at a high angle; and the drill-hole dipped at about 75° , the structural fabric elements S_1 and S_2 dipped toward 185° no matter how the core was oriented.

But B.V.H. from previous experience and looking at core above thought the symmetry was Z. This was therefore recorded as:

Core	From		To		Feature	#	S ₁		S ₂		Bedding S ₀		
	Dip		Dip				Dip Direct.		Dip Direct.		Dip Direct.		
1	10	14	16	20	22	24	26	28	32	34	38	40	44
S				5,000	F, Z			8,0	1,8	5	8,0	1,8	5

For each of S₁ and S₂ there were two possible ways to plot the data:



Both options were plotted because the R.F.E. dipped toward 185° no matter how the core was oriented. But Z was plotted beside the ticks to remind B.V.H. what he thought was the solution in the field. Either way, without referring to the log it was unknown which S₁ went with which S₂.

Appendix II*

LITHOSTRATIGRAPHIC COLUMN

GATAGA AREA (KECHIKA TROUGH)

April 1981

<u>Symbol</u>	<u>Colour</u>	<u>Lithology</u>
<u>RECENT</u>		
OB		- undivided overburden
OB _{SC}		- soil - C- horizon or scree
OB _{RG}		- River gravel
OB _{TL}		- Till
<u>LATE TERTIARY - Normal Faulting</u>		
---- U	935	- Tectonic breccia of lithology designated in first four spaces
---- F	935	- Shear and gouge zone of lithology designated in first four spaces
<u>CRETACEOUS to EARLY TERTIARY - Laramide Orogeny</u>		
F ₁ (feature)		- First phase Laramide folds
S ₁ (feature)		- First phase axial planar cleavage
<u>TRIASSIC (TR)</u>		
TR _{RC}	945 (striped)	- Chert: irregularly ribbon bedded with large composite nodules, graphitic partings
TR _{CB}	945 (striped)	- Carbonate: limestone to dolostone, buff to light grey weathering, with locally abundant <u>Monotis</u>
TR _{ML}	945 (striped)	- Marl: shaly limestone, thinly irregularly bedded with abundant <u>Monotis</u>
TR _{SH}	945 (striped)	- Shale: brown-grey to black, silty
<u>WARNEFORD FORMATION (DM_W)</u>		
DM _{WB}	920	- Shale: dark grey to black, gunsteel to rusty weathering, hard, graphitic, competent coring but phylitic lenticular cleavage when weathered; common intraformational breccia (DM _{WB1}) and/or chert and quartz sand to pebble conglomerate lenses (DM _{WBX}) on Fluke = DG _{GR} , DG _{PH} , DM _{WC} .
DM _{WR}	948	- Shale: soft, black, rusty-brown weathering, laminated, slaty cleaved
DM _{WT}	945	- Siltstone: light grey, speckled-weathering, soft, variably calcareous, pyrite, diffusely laminated -- "Conundrum Siltstone" on Elf, similar to DG _{SH} and DG _{SF}
DM _{WQ}	944	- Quartzarenite: black, light grey weathering, siliceous, graphitic, laminated, could be = DM _{WT}
DM _{WC}	965	- Conglomerate: chert granule to pebble, also breccia, varicoloured, black to light silvery-grey weathering
DM _{WP}	951	- Shale: dark brown-grey, rusty brown weathering, silty, distinctly laminated, -- "Pinstriped Shale"
DM _{WS}	947	- Shale: dark brown, rusty brown weathering, indistinctly bedded, with lithic sandstone and orange dolomitic siltstone interbeds

* Note: For chart correlating this with 1978, 1979, and 1980 legends see separate memo "Conversion of "L" Data From 1980 to 1981 Formats", April 1981.

GUNSTEEL FORMATION (DG, DB)

- DG_{GS} 910 - Shale: dark grey to black, silvery-grey weathering, laminated -- Undivided Gunsteel
- DG_{TB} 943 - Siltstone: light to medium grey, dolomitic, fine grained, homogeneous texture, commonly tectonic breccia
- DG_{GR} 911 - Shale: dark grey to black, rusty grey weathering, graphitic, competent, moderately hard, with discontinuous pyrite laminae. = DG_{PH}, = DM_{WB}
- DG_{PH} 920 - Shale: light to medium grey, silvery grey weathering, soft, lenticular cleaved, phyllitic, = DG_{PF}, = DM_{WB}, = DG_{GR}
- DG_{SH} 946 - Siltstone: light to dark grey, speckled, variably calcareous, planar to irregularly laminated, with phyllitic-graphitic lenticular cleavage = DG_{SF}
- DG_{CH} 934 - Porcellanite: dark grey to black, silvery grey weathering, ribbon bedded (<5cm), with graphitic shale partings and interbeds -- Hanging Wall Ribbon Chert = DG_{CF}
- DG_{TH} 913 - Shale to porcellanite: dark grey, silvery grey weathering, distinct graphitic partings <3cm apart, commonly <1cm; laminated, commonly with siltstone laminae (DG_{THT})-- Hanging Wall Poker Chip Shale = DG_{PR}; = DB, = DG_{TF}, = DA_{PC}
- DG_{PR} 908 - Shale to porcellanite: dark grey to black, silvery grey to rusty weathering, silty; bedding thicker than 3cm, massive to laminated; with or without nodules of barite, pyrite and calcite -- Pregnant Shale, = DM_{TH}, = DB, = D_{PR}
- DG_{LB} 942 - Pyrite: >10%, very fine-grained, very finely laminated, interlaminated with siliceous ± calcareous shale, in beds 1- to 20cm thick -- Laminar-Banded Pyrite
- DG_{SX} 944 - Siltstone: light to medium grey, laminated to bioturbated, dolomitic, siliceous common intraformational breccia (DG_{SXI}) and conglomerate = S_{SS}
- DG_{DL} 940 - Rhythmically interlaminated on a scale of about 1cm: siliceous siltstone, fine-grained laminated pyrite and black siliceous shale ± blebby barite -- Distinctly Laminated Unit
- DB_{PY} 916 - Pyrite: >80%, laminated, fine-grained
- DB_{BA} 939 - Barite: white to grey, fine-grained, laminated, common shale partings
- DB_{VN} 929 - Barite: medium to coarsely crystalline, common galena in strain shadows and irregular patches, in veins and swells: = barite talus slope at Cirque and Elf showing
- DB_{ES} 923 - Massive crystalline galena + sphalerite + calcite + barite + minor pyrite, generally laminated, interbedded with Pregnant Shale on a scale of 1 to 10cm -- Elf showing and drill core
- DB_{MS} 925 - Pyrite, sphalerite and galena: massive, medium to coarsely crystalline, minor barite
- DB_{SB} 922 - High grade sphalerite, galena and pyrite with 20% < barite < 60%: crudely laminated, crystalline
- DB_{BX} 921 - Intraformational breccia of barite, often with siltstone fragments, locally coarse crystalline, with <40% irregular laminae and matrix of pyrite.
- DB_{BS} 918 - Barite with <40% pyrite and minor ZnS, PbS: finely crystalline, irregular to discontinuously interlaminated; minor barite nodules
- DG_{TF} 912 - Shale to porcellanite: dark grey to black, silvery weathering, distinct graphitic partings <3cm apart, commonly 1cm, internally finely laminated, common siltstone laminae -- Footwall Poker Chip Shale = D_{PC}, DG_{TH}
- DG_{SF} 943 - Siltstone: light to dark grey, speckled, variably calcareous, planar to irregularly laminated, with phyllitic-graphitic lenticular cleavage partings = DG_{SH}, DM_{WT}
- DG_{CF} 956 - Porcellanite: dark grey to black, silvery-grey weathering, ribbon bedded (<5cm), with graphitic shale interbeds and partings -- Footwall Ribbon Chert = DG_{CH}
- DG_{PF} 920 - Shale: grey, gunsteel to rusty weathering, soft, phyllitic, lenticular cleaved = DG_{PH}

AKIE SHALE (DA)

- DA_{SL} 941 - Shale: grey, grey weathering, silty, laminated and often distinctly bedded - undivided Akie Shale
- DA_{PC} 964 - Shale: black, graphitic, poker chip partings, with common light grey siltstone beds = DG_{TF}
- DA_{PR} 933 - Shale: black, siliceous, massive coring, with common siltstone, pyrite laminae, = DG_{PR}
- DA_{CG} 944 - Conglomerate: chert and siliceous siltstone fragments, could = LD_{PX}
- DA_{SS} 943 - Siltstone: medium grey, dolomitic, laminated, includes intraformational breccias - commonly at gradational to sharp contact between Devonian shale and S₅

-----unconformity-----

KWADACHA and PESIKA REEFS - Lower to Middle Devonian Limestone

D_{KR} 919 - Limestone: grey, thick, massive bedded, fossiliferous - stromatoporoid, coral, crinoid debris with some fossils in growth position

PAUL RIVER FORMATION - Lower (LD_p) to Middle (D_p) Devonian Shale

D_{PP} 930 - Porcellanite: ribbon bedded, with fossiliferous limestone breccia beds (East Cirque).
 D_{PL} 906 - Shale: black, with thin fossiliferous limestone turbidites, commonly with two-holed crinoids
 LD_{PX} 906 - Siltstone to breccia: thin to thick graded beds, clasts of chert, quartz sand and shale chips, interbedded with black graptolitic shale -- Elf only, isolated outcrops, could be = DA_{CG}
 LD_{PQ} 919 - Quartzite: grey, dolomitic, some fossil debris, rhythmically interbedded with black graptolitic shale
 LD_{PS} 965 - Shale: black, graphitic, graptolitic, variably calcareous -- undivided Paul River Formation

SILURIAN SILTSTONE (S_S)

S_{SH} 940 - Siltstone: shaly, recessive, laminated
 S_{SS} 940 - Siltstone: light orange-weathering, dolomitic
 S_{SO} 940 - Sandstone: quartzose, with coral and sponge fragments; rhythmic, massive graded beds; interbedded with black siltstone and shale
 S_{SL} 940 - Limestone: grey weathering, laminated, silty

— — — — — unconformity — — — — —

ROAD RIVER GROUP (OS_R; S_R)

S_{RC} 932 - Porcellanite (S_{RCS}): streaky white-striped, ribbon bedded, with black calcareous graptolitic shale partings, some dolomitic siltstone (S_{REB}) and large limestone concretions (S_{RCA}) -- Silurian Ribbon Chert
 S_{RL} 903 - Limestone: grey, rhythmic, flaggy to blocky bedded, calcisiltite and fine calcarenite turbidites with graptolitic shale interbeds -- Silurian Limestone
 OS_{RG} 967 - Shale: black, silvery-grey to black weathering, graptolitic, minor chert
 OS_{RQ} 963 - Quartzose sandstone turbidites with minor carbonate fossil fragments and graptolitic shale interbeds
 OS_{RT} 905 - Limestone: rhythmically bedded turbidites and shale
 OS_{RS} 904 - Dolostone: orange-weathering, silty
 OS_{RC} 933 - Porcellanite: black, ribbon bedded, with limestone concretions
 OS_{RR} 936 - Shale: black, buff to light grey weathering, graptolitic, commonly calcareous -- undivided Road River

SKOKI FORMATION (O_{SK})

O_{SK} 901 - Dolostone: grey-buff laminated flaggy beds and intraformational breccia (O_{SKL}, O_{SKI}) or interbedded graptolitic shale and dolostone breccia with abundant corals and crinoids (O_{SKX}) or massive bedded fossiliferous dolostone -- Skoki Formation (O_{SKM}).

MENZIE CREEK FORMATION (O_V)

O_{VF} 937 - Massive mafic to andesitic flows, locally amygdaloidal and phylitic
 O_{VX} 937 - Mixed volcanic and shale intraclast breccia and conglomerate
 O_{VT} 937 - Tuff and breccia: orange-weathering, flattened, siliceous (O_{VTS}) to highly calcareous (O_{VTK})
 O_{VG} 937 - Gabbroic-textured mafic sill or flow

KECHIKA GROUP (EO_K, O_K)

O_{KU} 902 - Limestone: yellowish weathering, grey-brown, nodular, argillaceous
 EO_{KL} 902 - Limestone: distinctly bedded, grey, phylitic, nodular, argillaceous

CAMBRIAN (LE, ME)

ME_{LR} 902 (striped) - Limestone: grey, aphanitic with tiny trilobites -- Middle Cambrian Reefs
 LE_{AO} 928 - Rhythmically interbedded orange-weathering dolostone and quartzarenite with Skolithos -- Atan Group
 LE_{AS} 928 - Shale: siliceous, silty, laminated -- Atan Group

MODIFIERS

E	homotaxial to
*	lithology identical to, but stratigraphic position different from
A	Calcite nodules
B	Barite nodules
C	Chert nodules
D	Dolomitic
E	
F	Highly foliated - when alone denotes FAULT shear zone
G	Carbonaceous or graphitic
H	Interbedded with shale
I	Intraformational breccia/conglomerate
J	Shaly
K	Calcareous
L	Laminated
M	Massive bedded
N	Nodular pyrite
O	Silty
P	Laminar banded pyrite
Q	Quartzose
R	Disseminated pyrite
S	Siliceous
S	Non-siliceous
T	Siltstone laminae (calcareous and non-calcareous) - usually turbidites
U	Tectonic (U-) Breccia - when alone denotes FAULT breccia
V	Volcaniclastic or tuffaceous
W	Bioturbated ("WORMY")
X	With conglomerate interbeds
Y	Pyrite laminae (individual)
Z	

ANVIL RANGE LITHOSTRATIGRAPHIC CODE

Eagle
Prismacolor
No.

938	11Q	BULL QUARTZ VEIN, POO	
932	11G	PYROXENITE AND SERPENTINIZED EQUIVALENTS	
937	11F	SMOKEY QUARTZ - FELDSPAR PORPHYRY	
934	11E	PORPHYRITIC HB - BIO QUARTZ DIORITE	
956	11D	EQUIGRANULAR HB - BIO QUARTZ DIORITE	
939	11C	QUARTZ MONZONITE PEGMATITE DIKES	
929	11B	PORPHYRITIC, BIOTITE - QUARTZ MONZONITE	
928	11A	MUSCOVITE - BIOTITE GRANODIORITE	
942	10	UNDIFFERENTIATED POLYMICITIC CONGLOMERATE	Pelly Formation
917	9H	GRAYWACKE, SHALE, MINOR CONGLOMERATE	
918	9G	THICKBEDDED SILTSTONE	
940	9F	FLYSCH FACIES GRAYWACKE AND SHALE	
914	9E	BASALTIC GRAYWACKES AND ARGILLACEOUS CHERTS	
909	9D	BASALT FLOWS	
968	9C	VARICOLORED RIBBON CHERTS AND NON - CALCAREOUS PHYLLITE	
961	9B	INTERBEDDED CARBONACEOUS LIMESTONE AND GRAPHITIC PHYLLITE	
925	9A	RUSTY WEATHERING, FINE GRAINED, POLYMICITIC CONGLOMERATE	
907/950	8G	ECLOGITE	
907/931	8F	BASALT	
933	8E	HARZBURGITE	
965	8D	DIABASE	
907	8C	GABBRO	
924	8B	RODINGITE	
933	8A	SERPENTINITE	
931	7A	MASSIVE AND FRAGMENTAL BASALT FLOWS	
905	6I	CALC - SILICATE PHYLLITE / ARGILLITE	
912	6H	TUFF TO TUFFACEOUS CHERT	Rose Creek Formation
930	6G	MAROON CHERT	
951	6F	VARICOLOURED PHYLLITIC CHERT / QUARTZITE	Kalzas Formation
919	6E	MARBLE / PHYLLITIC MARBLE	
940	6D	BARITE - 2	
921	6C	CHERT GRANULE / PEBBLE CONGLOMERATE / QUARTZITE	Crystal Peak Formation
942	6B	BARITE - 1	
962	6A	CARBONACEOUS TO GRAPHITIC, GREY SILICEOUS ARGILLITE / PHYLLITE	Pisswick Pond Formation
962	5I	CARBONACEOUS TO GRAPHITIC, ARGILLITE / PHYLLITE	
911	5H	AMYGOALOIDAL CHLORITIC PHYLLITE	
949	5G	VARIABLY CALCAREOUS, GRAPHITIC PHYLLITE	
945	5F	CHLORITIC PHYLLITE	
904	5E	PHYLLITIC MARBLE AND SILICATED MARBLE	
910	5D	LAMINARLY BANDED, VARIABLY CALCAREOUS, CHLORITIC PHYLLITE	
908	5C	METABASITE	
920	5B	CALCAREOUS MUSCOVITE CHLORITE ± BIOTITE PHYLLITE	
936	5A	VARIABLY CALCAREOUS, GRAPHITIC PHYLLITE HOST TO UNIT 4	
923	4	GRUM, VANGORDA, DY, FIRTH, SWIM, SB, SEA SULPHIDE DEPOSITS UNDIFFERENTIATED	
916	3I	GRAPHITIC QUARTZITE IN NON - CALCAREOUS PHYLLITE / SCHIST	
913	3H	TUFFACEOUS CALC - SILICATE PHYLLITE / SCHIST (ASSOCIATED WITH 3D)	
941	3G	NON - CALCAREOUS, MUSCOVITE - CHLORITE ± BIOTITE PHYLLITE / SCHIST, UNDIFFERENTIATED	
906	3F	MARBLE AND SILICATED MARBLE	
963	3E	GRAPHITIC PHYLLITE / SCHIST	
913	3D	CALC - SILICATE PHYLLITE / SCHIST	
908	3C	METABASITE	
946	3B	CHLORITIC PHYLLITE / SCHIST	
912	3A	TRANSITION ZONE WITH UNIT 1	
923	2	FARO SULPHIDE DEPOSIT UNDIFFERENTIATED	
901	1G	MARBLE AND SILICATED MARBLE	
908	1F	METABASITE	
967	1E	GRAPHITIC SCHIST	
947	1D	CARBONACEOUS, BIOTITE - MUSCOVITE - ANDALUSITE SCHIST	
943	1C	QUARTZO - FELDSPATHIC, BIOTITE - MUSCOVITE GNEISS / SCHIST	
902	1B	TACTITE AND SILICATED MARBLE	
943	1A	UNDIFFERENTIATED UNIT 1	
907/950	0G	ECLOGITE	
933	0F	SERPENTINIZED ULTRAMAFIC METABASITE	
908	0E	METABASITE	
966	0D	GRAPHITIC PHYLLITE / SCHIST	
948	0C	VARIABLY CALCAREOUS MUSCOVITE - CHLORITE ± BIOTITE PHYLLITE / SCHIST	
915	0B	VARIABLY CARBONACEOUS, CALCAREOUS QUARTZITES / GRITS	
915	0A	UNDIFFERENTIATED UNIT 0	

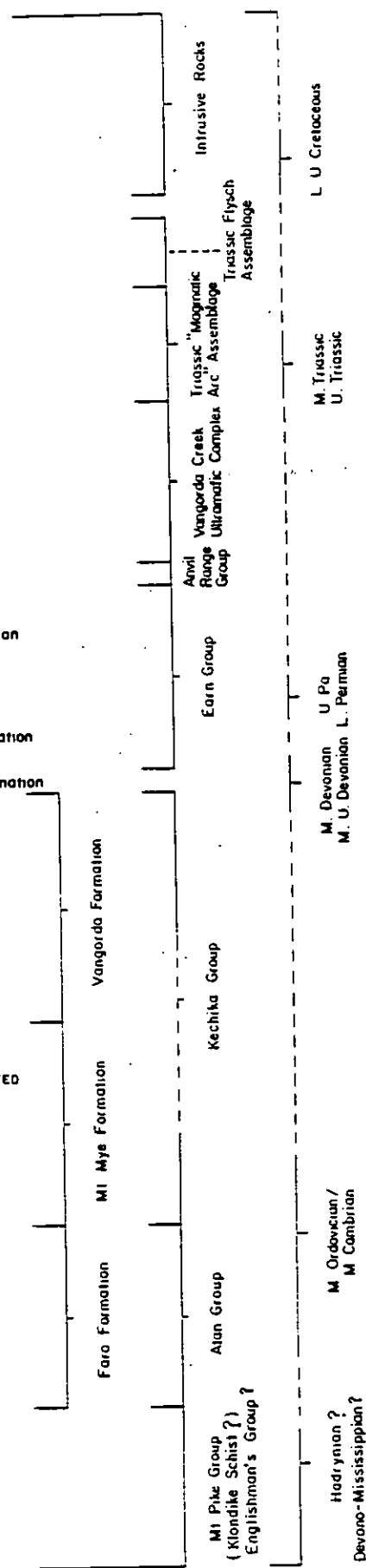

L U Cretaceous
M. Trassic
U. Trassic
M. Devonian
U. Pa.
M. Devonian
M. U. Devonian
L. Permian
M. Ordovician /
M. Cambrian
Hadrynian?
Devonian - Mississippian?

Appendix III

YANGORDA PLATEAU AREA
LITHOSTRATIGRAPHIC CODE

APRIL 1, 1981

Intrusive Rocks:

Unit 10	928	10-A	Granodiorite (kspars < plag, qtz > 10%)
	929	B	Adamellite (qtz monzonite)
	939	C	Pegmatite
	956	D	Quartz diorite (kspars << plag, qtz > 10%)
	934	E	Diorite (kspars << plag, qtz > 10%)
	925	F	Monzonite (kspars ~ plag, qtz < 10%)
	932	G	Pyroxenite
	937	H	Granite (kspars > plag, qtz > 10%)
	930	I	Syenite (kspars > plag, qtz < 10%)
	938	Q	Bull qtz veins/pods

- 1 Foliated/lineated
- 2 Porphyritic
- 3 Aphanitic
- 4 Smokey qtz-bearing
- 5 Muscovite-bearing
- 6 Kspars-bearing
- 7 Biotite-bearing
- 8 Amphibole-bearing
- 9 Altered (kaolinite, montmorillonite)
- 0 Normal (equigranular)

Yangorda Formation

Unit 5	936	S-A	Variably calcareous, graphitic phyllite (hosts Unit 4)
	920	B	Calcareous muscovite-chlorite - biotite phyllite
	909	C	Metabasite
	910	D	Laminarily banded, variably calcareous, chloritic phyllite
	904	E	Phyllitic marble and silicified marble
	945	F	Chloritic phyllite
	949	G	Variably calcareous, graphitic phyllite

Intrusive Contact

- 1 Siliceous
- 2 Carbonaceous
- 3 Calcareous
- 4 Altered, pyritic (white mica envelope)
- 5 Banded/laminated
- 6 Non-Calcareous
- 7 Tuffaceous
- 8 Chloritic
- 9 Sulfide-bearing
- 0 Normal

DY. Grm. Yangorda Deposits:

Unit 4	922	4-A	Sulfide-bearing, ribbon-banded, graphitic quartzite
	915	B	Pyrite-free quartzite (may contain base metal sulfides)
	916	C	Base metal-poor, pyritic quartzite
	942	D	Base metal-bearing, pyritic quartzite
	918	E	Massive pyritic sulfides
	923	F	Buckshot facies, massive sulfides
	928	G	Baritic facies, massive sulfides/sulfates (>10% BaSO ₄)
	924	H	Pyrrhotitic facies, massive sulfides
	924	J	Non-pyritic, massive sulfides/oxides
	921	K	Carbonate-bearing, massive pyritic sulfides

Conformable Contact

- 1 Siliceous
- 2 Coarse, porphyroblastic pyrite-bearing
- 3 Fine pyrite/marcasite-bearing
- 4 Sphalerite and/or galena-bearing
- 5 Carbonaceous
- 6 Baritic-bearing
- 7 Pyrrhotite-bearing
- 8 Magnetite-bearing
- 9 Chalcopyrite-bearing
- 0 Normal

914 4-L Muscovite > qtz. - chl. phyllite (generally sulfide bearing)

- 1 Siliceous
- 2 Pyrite-bearing
- 3 Calc-bearing (white mica envelope)
- 4 ZnS and/or PbS-bearing
- 5 Carbonate-bearing
- 6 Chl > qtz-musc phyllite
- 7 Pyrrhotite-bearing
- 8 Magnetite-bearing
- 9 Chalcopyrite-bearing
- 0 Normal

Mt. Nye Formation:

Unit 3	912	J-A	Transition zone with Unit 1
	946	B	Chloritic phyllite/schist
	908	C	Metabasite
	913	D	Calc-silicate phyllite/schist
	963	E	Graphitic phyllite/schist
	906	F	Marble and silicified marble
	941	G	Non-calcareous, muscovite-chlorite - biotite phyllite/schist undifferentiated
	913	H	Tuffaceous calc-silicate phyllite/schist (associated with J-D)
	916	I	Graphitic quartzite in non-calcareous phyllite/schist

- 1 Siliceous
- 2 Non-calcareous
- 3 Calcareous
- 4 Altered, pyritic (white mica envelope)
- 5 Banded/laminated
- 6 Sulfide-bearing
- 7 Tuffaceous
- 8 Chloritic
- 9 Carbonaceous
- 0 Normal

CALC-SILICATE PHASES

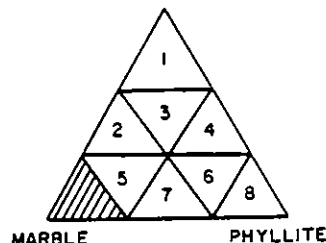

Appendix III

BY DEPOSIT AREA

LITHOSTRATIGRAPHIC CODE

Intrusive Rocks

Unit 11	928	J A
	929	B
	939	C
	936	D
	934	E
	937	F
	932	G
	938	O
		1
		2
		3
		4
		5
		6
		7
		8
		9
		0

Muscovite-biotite granodiorite
Porphyritic, biotite-quartz monzonite
Quartz monzonite pegmatite dikes
Equigranular hb-bio quartz diorite
Porphyritic hb-bio quartz diorite
Sackey quartz-feldspar porphyry
Pyroxenite and serpentinized equivalents
Bull quartz vein, pod
Gnaissose LS - tectonite
Gnaissose L - tectonite
Equigranular
K - feldspar phenocrysts
Garnet-quartz-monzonite
Plagioclase phenocrysts
Plagioclase + biotite phenocrysts
Plagioclase + biotite + hornblende phenocrysts
Strongly altered
Normal

Arvill Batholith
Dioritic Suite
Related to Arvill Batholith
Arvill Batholith
Varieties
Diorite Porphyry
Varieties

Intrusive Contact

Vanguarda Formation

Unit 5	938	S A
	920	B
	908	C
	910	D
	904	E
	945	F
	940	G
	911	H
	962	I
		1
		2
		3
		4
		5
		6
		7
		8
		9
		0

Variably calcareous, graphitic phyllite (hosts Unit 4)
Calcareous muscovite-chlorite + biotite phyllite
Metabasite
Laminarily banded, variably calcareous, chloritic phyllite
Phyllitic marble and silicified marble
Chloritic phyllite
Variably calcareous, graphitic phyllite
Amphiboloidal chloritic phyllite
Carbonaceous to graphitic argillite/phyllite
Siliceous
Carbonaceous
Calcareous
Altered, pyritic (white silica envelope)
Banded/laminated
Non-calcareous
Tuffaceous
Chloritic
Sulfide-bearing
Normal

Conformable Contact

DX Deposits

Unit 4	922	4 A
	915	B
	916	C
	942	D
	918	E
	923	F
	928	G
	924	H
	921	I
	914	J
		1
		2
		3
		4
		5
		6
		7
		8
		9
		0

Sulfide-bearing, ribbon-banded, graphitic quartzite
Pyrite-free quartzite (may contain base metal sulfides)
Base metal-poor, pyritic quartzite
Base metal-bearing, pyritic quartzite
Massive pyritic sulfides
Buckshot facies, massive sulfides
Baritic facies, massive sulfides/sulfates (>10% BaSO₄)
Pyrrhotitic facies, massive sulfides
Non-pyritic, massive sulfides/oxides
Carbonate-bearing, massive pyritic sulfides
Sulfide-bearing siliceous to tuffaceous schists
Siliceous
Coarse, porphyroblastic pyrite-bearing
Fine pyrite/marcasite-bearing
Sphalerite and/or galena-bearing
Carbonaceous
Barite-bearing
Pyrrhotite-bearing
Magnetite-bearing
Chalcopyrite-bearing
Normal

Banded
Massive

Conformable Contact

NE. Nye Formation

Unit 3	912	J A
	946	B
	908	C
	913	D
	963	E
	906	F
	941	G
		H
	916	I
		1
		2
		3
		4
		5
		6
		7
		8
		9
		0

Transition zone with Unit 1
Chloritic phyllite/schist
Metabasite
Calc-silicate phyllite/schist
Graphitic phyllite/schist
Marble and silicified marble
Non-calcareous, muscovite-chlorite + biotite
phyllite/schist, undifferentiated
Tuffaceous calc-silicate phyllite/schist
(associated with D)
Graphitic quartzite in non-calcareous phyllite/schist
Siliceous
Non-calcareous
Calcareous
Altered, pyritic (white silica envelope)
Banded/laminated
Sulfide-bearing
Tuffaceous
Chloritic
Carbonaceous
Normal

CALC-SILICATE PHASES

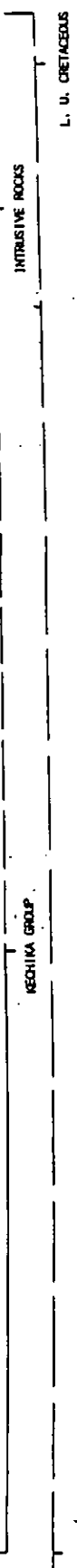
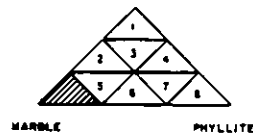

APPENDIX IV: DRILL-HOLE IDENTIFICATION CODES, 1981

Anvil District:

GRUM EA 81 G
 FA 81 A, U

Between GRUM and VANGORDA

FA 81 AX__ (leave space for only 1 to 9 holes)

VANGORDA EA 81 V
 FA 81 V
 FA 81 VX__ (outside Vangorda, only 1 - 9 holes)

DY EA 81 X

SWIM EA 81 S

FARO EA 81 F

Tenas District:

ET 81 T

Gataga District:

CIRQUE EG 81 C

FLUKE EG 81 F

ELF EG 81 E

Coal Properties:

TULAMEEN EC 81 T

CARMACKS EC 81 C

ROSS RIVER EC 81 R

Pelly Properties:

MM EP 81 MM

Shannon Creek District:

SHANNON CREEK ES 81 SH__ (only 1 - 9 holes)

Anmac District:

KLUNK RIP

HY EM 81 H (Exploration MacMillan)

SUN - MOON EM 81 S