

006982

*Jaakko**B-7-405*

To L.P. TAGGART

---

From R. MURARKA

---

Date JANUARY 31, 1983

---

Subject COARSE LEAD FLOTATION

FILE: ~~E-2 314~~

I would like to make the following comments, if I may, on the KRAL report dated November 30, 1982:

1. In test #28 only 100 g/t of NaCN was added to the first stage of grinding. Also the finishing pH was too low (6.8). It is known that pH of 9 to 10 during grinding is optimum for CN<sup>-</sup> ion availability.

Since all NaCN in plant operation is added to the rod mill, similar practice should be used in the lab test (see attached figure).

2. Total Z-11 used in test #27 was 70 g/t as compared to 120 g/t in test #28.
3. In normal flotation lab test, pH conditioning should only be done before the first stage of flotation as is the case in plant operation.
4. In coarse lead flotation lab test, different splits of Z-11 addition to different stages may give different results.



---

R. MURARKA,  
METALLURGIST.

RM/df

# Normal Flotation

① Plant:

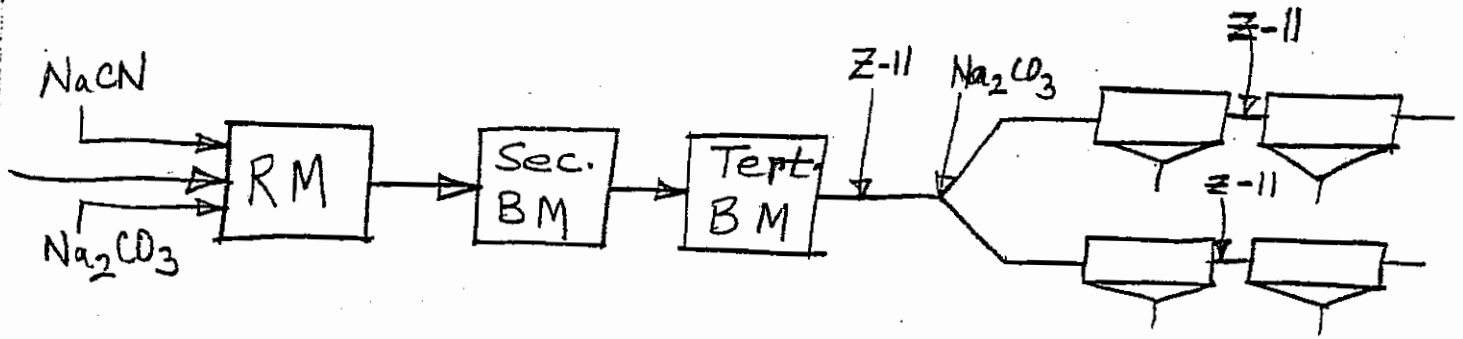

② Lab:

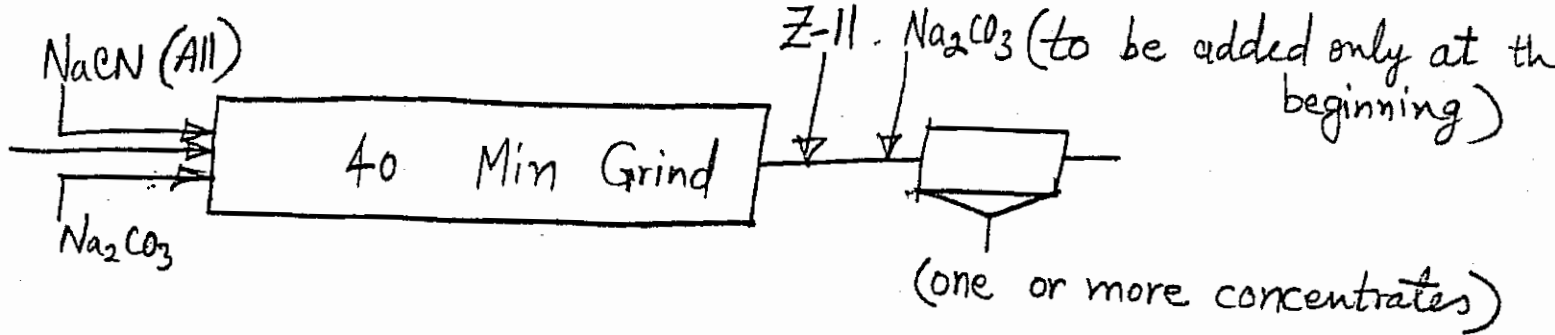

# Coarse Lead Flotation

① Plant:

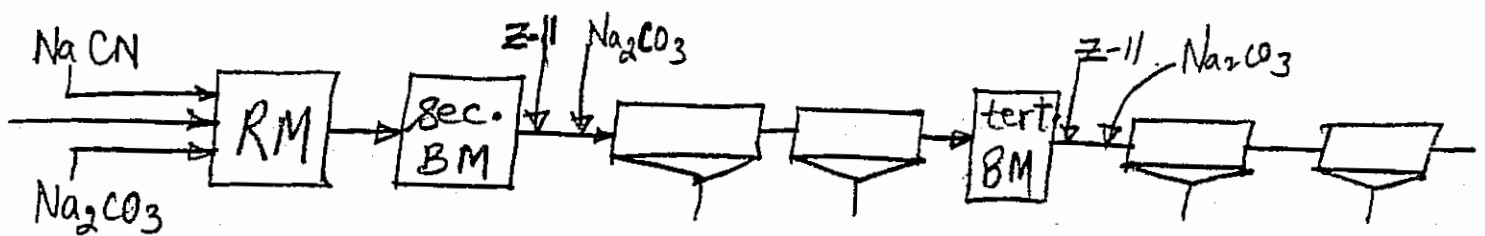

② Lab:

