

012946

REPORT ON INDUCED
POLARIZATION & RESISTIVITY
SURVEY
GRANITE MOUNTAIN PROJECT
115-I-6 & 7
McPhar Geophysics Limited
1966

REPORT ON THE
INDUCED POLARIZATION
AND RESISTIVITY SURVEY
AT THE
GRANITE MOUNTAIN PROJECT (VENTURE 79)
WHITEHORSE MINING DIVISION,
YUKON TERRITORY
FOR
CANEX AERIAL EXPLORATION LTD.

May 25th, 1970.

Dr. D. Drummond,
Canex Aerial Exploration Ltd.,
1030 West Georgia Street,
Vancouver, B.C.

Dear Daryl:

We have perused your reports on Granite Mountain and are returning them under this cover. We are unable to commit ourselves to any program at this time. However, we would like the opportunity to look at the ground in the event we would be in a position to participate in any deal your company may have to offer later this summer.

Yours truly,

ATLAS EXPLORATIONS LIMITED,

J. S. Brock,
Vice-President Exploration

JSB/mp
Encl.

McPHAR GEOPHYSICS LIMITED

NOTES ON THE THEORY OF INDUCED POLARIZATION AND THE METHOD OF FIELD OPERATION

Induced Polarization as a geophysical measurement refers to the blocking action or polarization of metallic or electronic conductors in a medium of ionic solution conduction.

This electro-chemical phenomenon occurs wherever electrical current is passed through an area which contains metallic minerals such as base metal sulphides. Normally, when current is passed through the ground, as in resistivity measurements, all of the conduction takes place through ions present in the water content of the rock, or soil, i. e. by ionic conduction. This is because almost all minerals have a much higher specific resistivity than ground water. The group of minerals commonly described as "metallic", however, have specific resistivities much lower than ground waters. The induced polarization effect takes place at those interfaces where the mode of conduction changes from ionic in the solutions filling the interstices of the rock to electronic in the metallic minerals present in the rock.

The blocking action or induced polarization mentioned above, which depends upon the chemical energies necessary to allow the ions to give up or receive electrons from the metallic surface, increases with the time that a d. c. current is allowed to flow through

the rock; i. e. as ions pile up against the metallic interface the resistance to current flow increases. Eventually, there is enough polarization in the form of excess ions at the interfaces to effectively stop all current flow through the metallic particle. This polarization takes place at each of the infinite number of solution-metal interfaces in a mineralized rock.

When the d. c. voltage used to create this d. c. current flow is cut off, the Coulomb forces between the charged ions forming the polarization cause them to return to their normal position. This movement of charge creates a small current flow which can be measured on the surface of the ground as a decaying potential difference.

From an alternate viewpoint it can be seen that if the direction of the current through the system is reversed repeatedly before the polarization occurs, the effective resistivity of the system as a whole will change as the frequency of the switching is changed. This is a consequence of the fact that the amount of current flowing through each metallic interface depends upon the length of time that current has been passing through it in one direction.

The values of the "metal factor" or "M. F." are a measure of the amount of polarization present in the rock mass being surveyed. This parameter has been found to be very successful in mapping areas of sulphide mineralization, even those in which all other geophysical methods have been unsuccessful. The induced polarization measurement is more sensitive to sulphide content than other electrical measurements

because it is much more dependent upon the sulphide content. As the sulphide content of a rock is increased, the "metal factor" of the rock increases much more rapidly than the resistivity decreases.

Because of this increased sensitivity, it is possible to locate and outline zones of less than 10% sulphides that can't be located by E. M. Methods. The method has been successful in locating the disseminated "porphyry copper" type mineralization in the South-western United States.

Measurements and experiments also indicate that it should be possible to locate most massive sulphide bodies at a greater depth with induced polarization than with E. M.

Since there is no I. P. effect from any conductor unless it is metallic, the method is useful in checking E. M. anomalies that are suspected of being due to water filled shear zones or other ionic conductors. There is also no effect from conductive overburden, which frequently confuses E. M. results. It would appear from scale model experiments and calculations that the apparent metal factors measured over a mineralized zone are larger if the material overlying the zone is of low resistivity.

Apropos of this, it should be stated that the induced polarization measurements indicate the total amount of metallic constituents in the rock. Thus all of the metallic minerals in the rock, such as pyrite, as well as the ore minerals chalcopryrite, chalcocite, galena, etc. are responsible for the induced polarization effect. Some

oxides such as magnetite, pyrolusite, chromite, and some forms of hematite also conduct by electrons and are metallic. All of the metallic minerals in the rock will contribute to the induced polarization effect measured on the surface.

In the field procedure, measurements on the surface are made in a way that allows the effects of lateral changes in the properties of the ground to be separated from the effects of vertical changes in the properties. Current is applied to the ground at two points a distance (X) apart. The potentials are measured at two other points (X) feet apart, in line with the current electrodes. The distance between the nearest current and potential electrodes is an integer number (N) times the basic distance (X).

The measurements are made along a surveyed line, with a constant distance (NX) between the nearest current and potential electrodes. In most surveys, several traverses are made with various values of (N); i. e. (N) = 1, 2, 3, 4, etc. The kind of survey required (detailed or reconnaissance) decides the number of values of (N) used.

In plotting the results, the values of the apparent resistivity and the apparent metal factor measured for each set of electrode positions are plotted at the intersection of grid lines, one from the center point of the current electrodes and the other from the center point of the potential electrodes. The resistivity values are plotted above the line and the metal factor values below. The lateral displacement of a given value is determined by the location along the survey

line of the center point between the current and potential electrodes. The distance of the value from the line is determined by the distance (NX) between the current and potential electrodes when the measurement was made.

The separation between sender and receiver electrodes is only one factor which determines the depth to which the ground is being sampled in any particular measurement. These plots then, when contoured, are not section maps of the electrical properties of the ground under the survey line. The interpretation of the results from any given survey must be carried out using the combined experience gained from field, model and theoretical investigations. The position of the electrodes when anomalous values are measured must be used in the interpretation.

In the field procedure, the interval over which the potential differences are measured is the same as the interval over which the electrodes are moved after a series of potential readings has been made. One of the advantages of the induced polarization method is that the same equipment can be used for both detailed and reconnaissance surveys merely by changing the distance (X) over which the electrodes are moved each time. In the past, intervals have been used ranging from 100 feet to 1000 feet for (X). In each case, the decision as to the distance (X) and the values of (N) is largely determined by the expected size of the mineral deposit being sought, the size of the expected anomaly and the speed with which it is desired to progress.

The diagram in Figure 1 below demonstrates the method used in plotting the results. Each value of the apparent resistivity and the apparent "Metal factor" is plotted and identified by the position of the four electrodes when the measurement was made. It can be seen that the values measured for the larger values of (n) are plotted farther from the line indicating that the thickness of the layer of the earth that is being tested is greater than for the smaller values of (n); i. e. the depth of the measurement is increased.

METHOD USED IN PLOTTING DIPOLE-DIPOLE
INDUCED POLARIZATION AND RESISTIVITY RESULTS

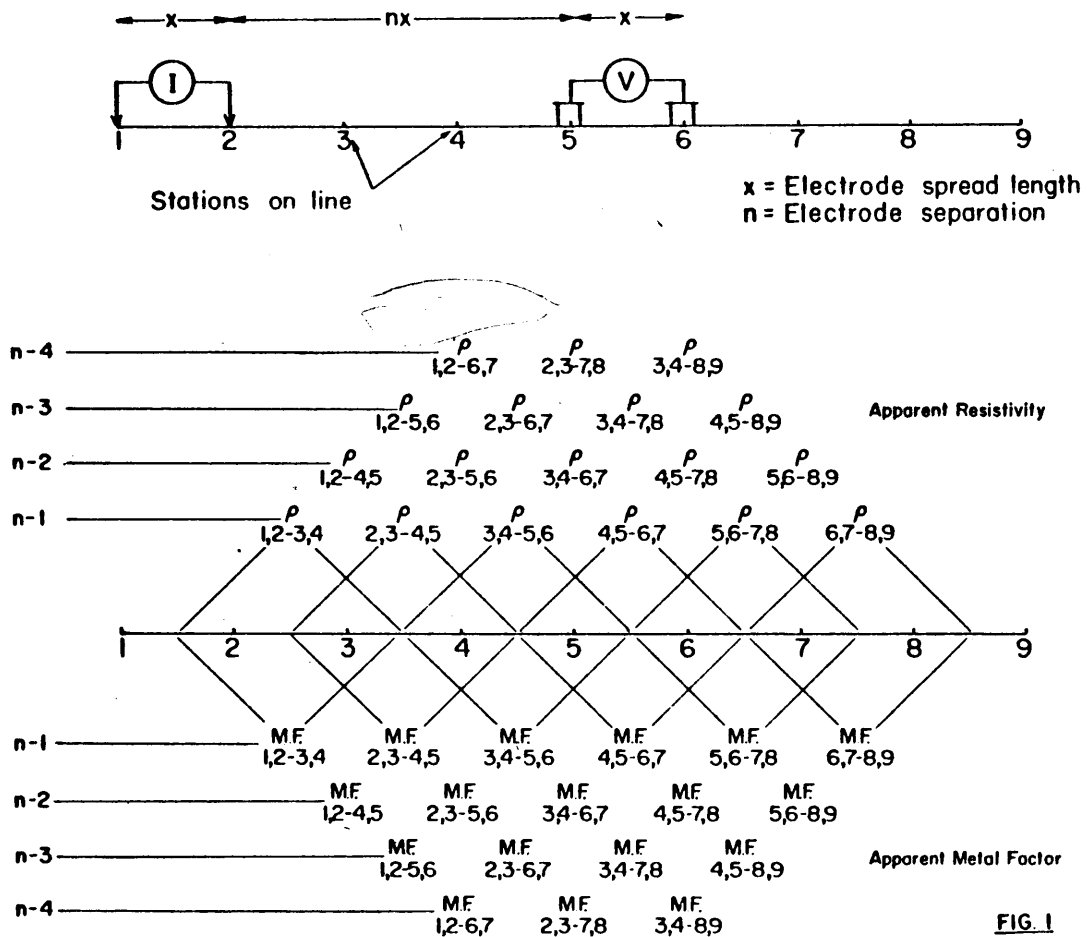

FIG. 1

McPHAR GEOPHYSICS LIMITED

REPORT ON THE
INDUCED POLARIZATION
AND RESISTIVITY SURVEY

AT THE
GRANITE MOUNTAIN PROJECT (VENTURE 79)
WHITEHORSE MINING DIVISION, YUKON TERRITORY

FOR
CANEX AERIAL EXPLORATION LTD.

1. INTRODUCTION

At the request of Canex Aerial Exploration Ltd., an induced polarization and resistivity survey has been carried out at the Granite Mountain Project. There is little outcrop in the area, but an extensive area is thought to be underlain by granitic rocks.

Geologic examinations by the Staff of Canex Aerial Exploration Ltd., have found copper mineralization in outcrops of the granitic rocks. The mineralization is only weakly disseminated, but geochemical results suggest that the copper bearing mineralization may be widespread. The induced polarization and resistivity survey was planned in an attempt to locate any unknown zones of metallic mineralization that might be present.

2. PRESENTATION OF RESULTS

The induced polarization and resistivity results are shown on the following enclosed data plots. The results are plotted in the manner described in the notes preceding this report.

Line 30E	300' electrode intervals	Dwg. IP 2534-1
Line 25E	300' electrode intervals	Dwg. IP 2534-2
Line 20E	300' electrode intervals	Dwg. IP 2534-3
	200' electrode intervals	Dwg. IP 2534-4
Line 15E	300' electrode intervals	Dwg. IP 2534-5
Line 10E	300' electrode intervals	Dwg. IP 2534-6
	200' electrode intervals	Dwg. IP 2534-7
Line 5E	300' electrode intervals	Dwg. IP 2534-8
	200' electrode intervals	Dwg. IP 2534-9
	100' electrode intervals	Dwg. IP 2534-10
Line 2+50E	300' electrode intervals	Dwg. IP 2534-11
Line 0+00	300' electrode intervals	Dwg. IP 2534-12
Line 5W	300' electrode intervals	Dwg. IP 2534-13
Line 10W	300' electrode intervals	Dwg. IP 2534-14
	200' electrode intervals	Dwg. IP 2534-15
Line 15W	300' electrode intervals	Dwg. IP 2534-16
Line 20W	300' electrode intervals	Dwg. IP 2534-17
Line 25W	300' electrode intervals	Dwg. IP 2534-18
Line 30W	300' electrode intervals	Dwg. IP 2534-19
Line 22N	300' electrode intervals	Dwg. IP 2534-20
	100' electrode intervals	Dwg. IP 2534-21

Also enclosed with this report is Dwg. Misc. 3205, a plan map of the line surveyed at a scale of 1" = 500'. The definite and possible induced polarization anomalies are indicated by solid and broken bars

respectively on this plan map as well as the data plots. These bars represent the surface projection of the anomalous zones as interpreted from the location of the transmitter and receiver electrodes when the anomalous values were measured.

Since the induced polarization measurement is essentially an averaging process, as are all potential methods, it is frequently difficult to exactly pinpoint the source of an anomaly. Certainly, no anomaly can be located with more accuracy than the spread length; i. e. when using 300' spreads the position of a narrow sulphide body can only be determined to lie between two stations 300' apart. In order to locate sources at some depth, larger spreads must be used, with a corresponding increase in the uncertainties of location. Therefore, while the center of the indicated anomaly probably corresponds fairly well with source, the length of the indicated anomaly along the line should not be taken to represent the exact edges of the anomalous material.

3. DISCUSSION OF RESULTS

The induced polarization survey at Granite Mountain has shown the widespread presence of disseminated metallic mineralization. The lateral extent of the anomalies can be seen on Dwg. Misc. 3205. The anomalies are of widely varying magnitudes; in a limited area, in which the mode of mineralization can be expected to be similar; the magnitude of the IP anomalies will reflect the concentration of metallic mineralization present.

There are broad areas in which the IP results suggest the

presence of weak mineralization in the range of 1% to 2% (Line 30E, 20N to 33N; Line 5E, 30N to 36N; Line 20W, 24N to 30N.) Within these extensive weak anomalies, there are more limited zones of much higher IP effects. These larger magnitude zones are shown on the plan map.

Within these zones, the concentration of metallic mineralization may be 3% to 6%. The results shown in Case History XXIII and Case History XXIV show the IP effects measured from concentrations of approximately 4% metallic mineralization in granitic rocks. The stronger IP anomalies located at Granite Mountain are very similar to those shown.

The most definite mineralization found in place on the Granite Mountain Project is at about 7N on Line 5E. The 300' spread results show a weak anomaly at this location; the detailed measurements with shorter electrode intervals show very weak, irregular IP effects. The mineralization observed in the outcrop must be very weakly disseminated, or present in only a very small volume.

4. CONCLUSIONS AND RECOMMENDATIONS

The extensive metallic mineralization indicated by the IP anomalies shown on Dwg. Misc. 3205 is probably mostly pyrite. The IP data shown in Case History XXIII and Case History XXIV shows that IP anomalies from zones containing copper can not be distinguished from these due to pyrite alone. The available geological and geochemical information may help somewhat; however, it is probable that drill holes will have to be used to determine the mineralization causing the IP anomalies.

INDUCED POLARIZATION AND DRILLING RESULTS FROM ZONE OF DISSEMINATED MINERALIZATION QUARTZITE, ARIZONA

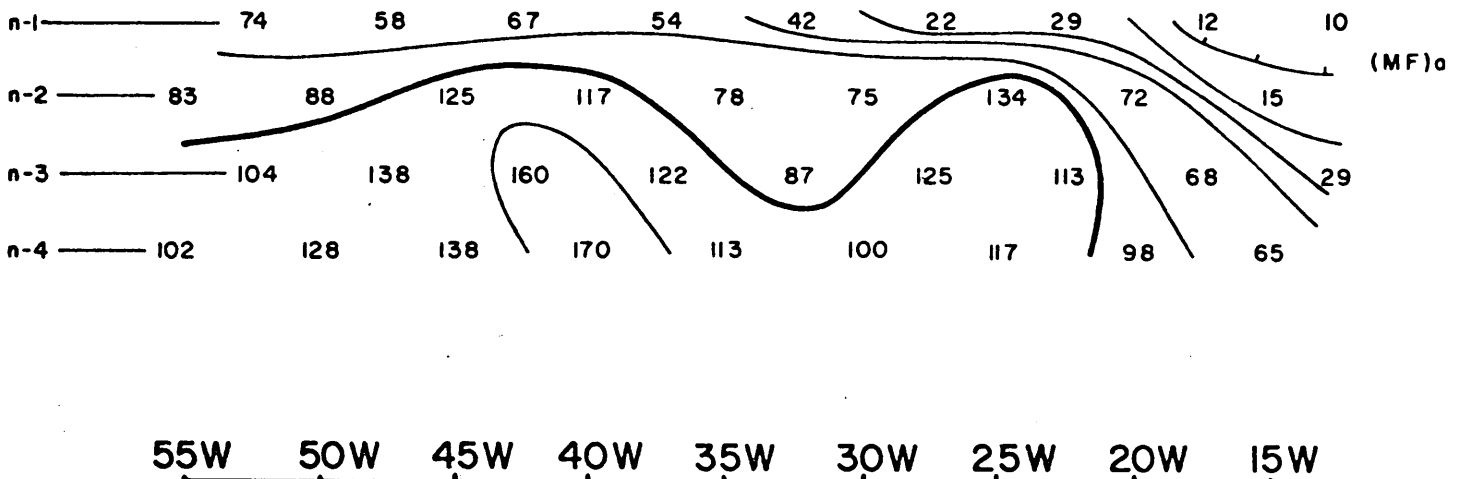
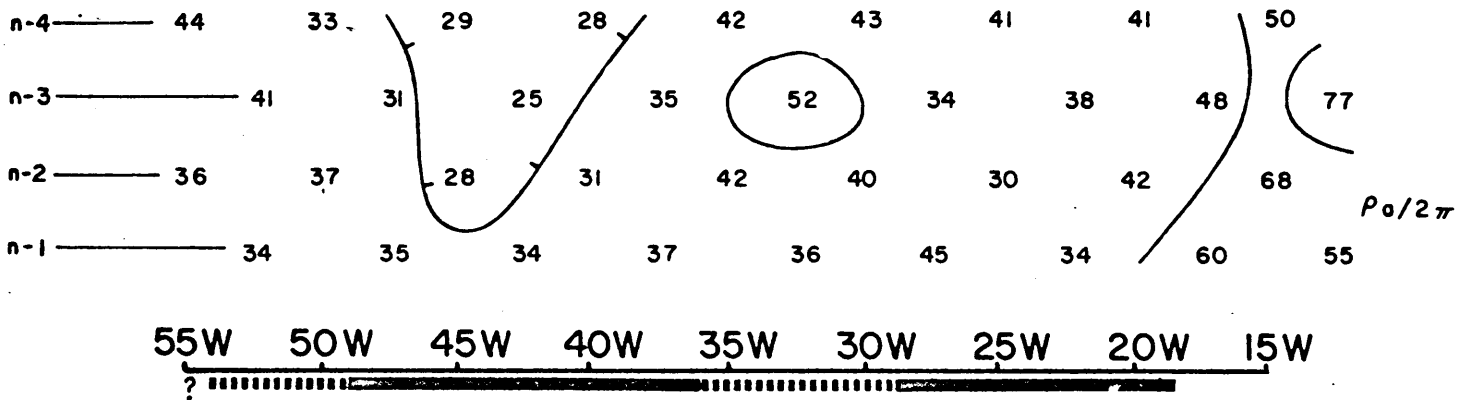

55W 50W 45W 40W 35W 30W 25W 20W 15W

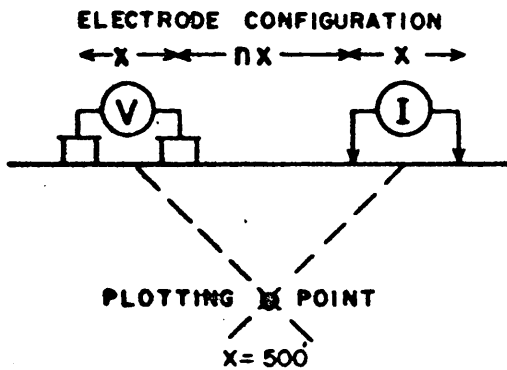
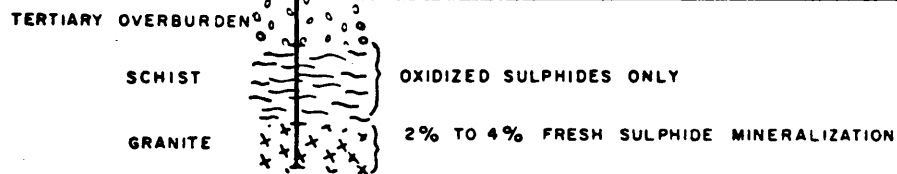

INDUCED POLARIZATION AND DRILLING RESULTS FROM COPPER MOUNTAIN OREBODY GASPE AREA, QUEBEC

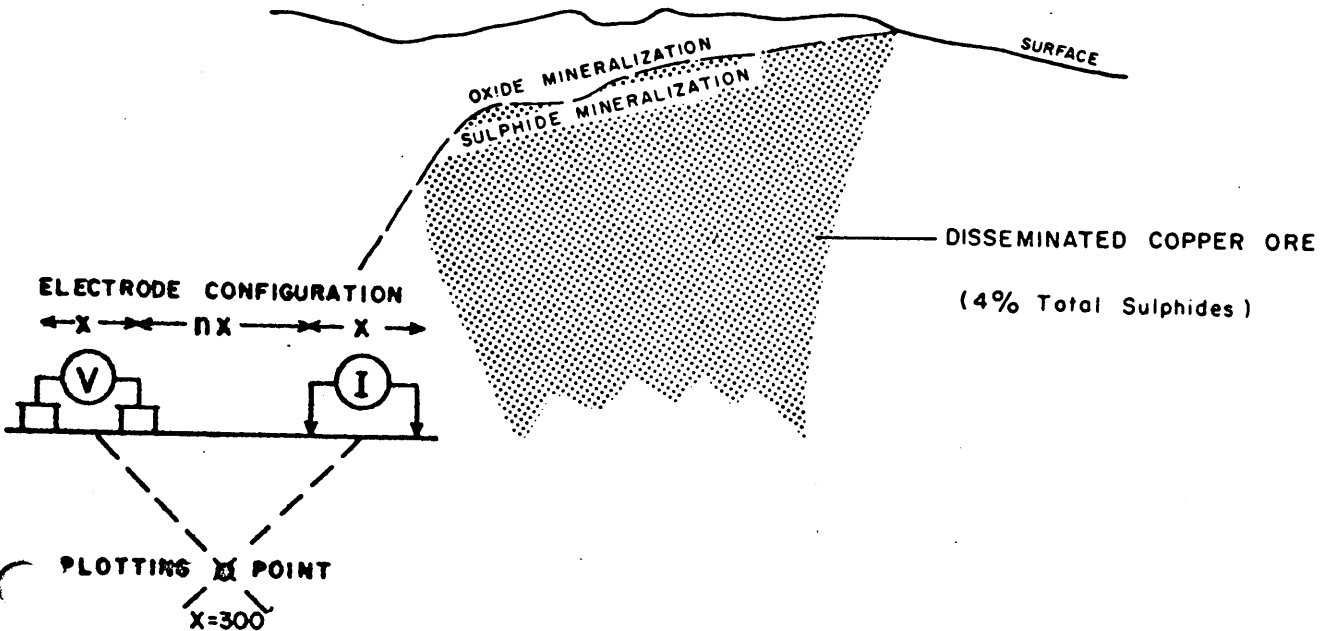
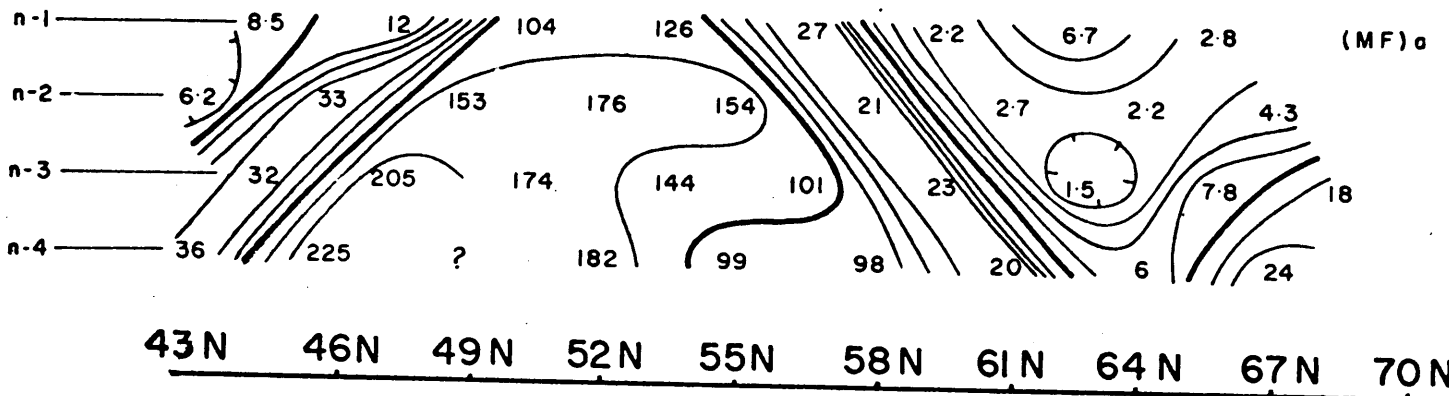
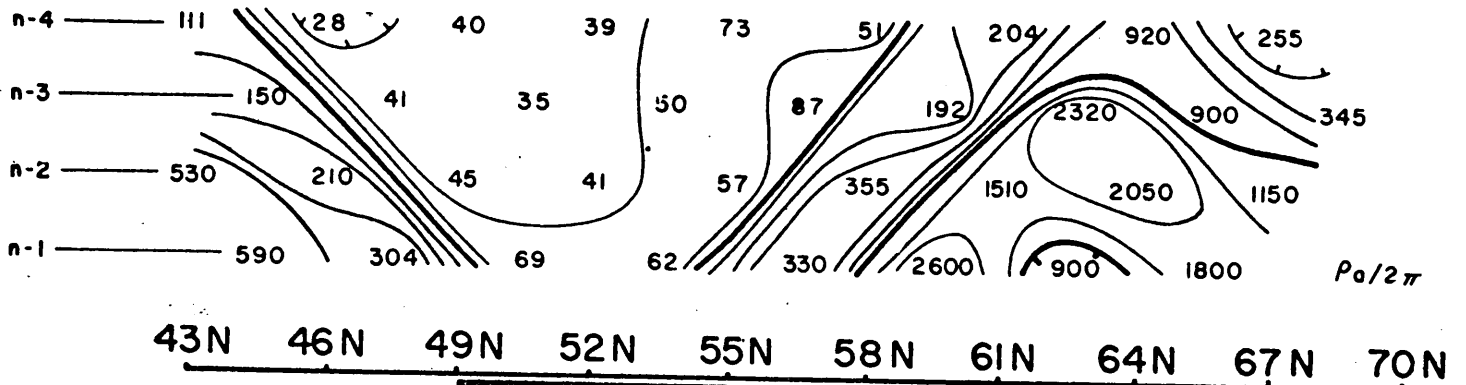

In most cases, the amount of chalcopyrite present is in a constant ratio to the pyrite content; i. e. the highest copper assays can be expected within the largest magnitude IP anomalies. This is not always true, however. It is not true, for instance, at the copper deposit recently found by the Stikine Copper Company at Galore Creek, B. C. In many disseminated sulphide deposits containing molybdenum, the most concentrated molybdenite is not with the most concentrated pyrite. There is a definite "halo" effect for the pyrite mineralization.

These facts must be kept in mind when evaluating the IP anomalies located at Granite Mountain. It is recommended that several drill holes be planned to test the mineralization within Zone I and Zone III. The results from these holes would determine the need for further IP work and/or drilling.

The holes drilled can be either vertical, or angled. The sources of the anomalies are broad, and the holes are planned to test a volume of rock rather than to intersect a specific target.

a) Zone I

The results here show a gradual increase in the concentration of metallic mineral north of about 28N. The detailed results on Line 10W show the southern edge of the strong anomaly quite clearly. The mineralization is indicated to be at a shallow depth (measured for $n = 1$), so that the holes can be relatively short. The holes are spotted to test the most concentrated mineralization as well as the weaker mineralization to the south.

DDH No. 1	Line 10W, 32N to depth of 250 to 300 feet
DDH No. 2	Line 10W, 29N to depth of 250 to 300 feet
DDH No. 3	Line 10W, 26N to depth of 250 to 300 feet

b) Zone III

This definite zone has considerable areal extent. It could be of definite economic importance, if enough copper is present to make open-pit mining possible. On some lines, the results indicate that there is some depth to the top of the most concentrated mineralization. The drill holes must be somewhat longer.

DDH No. 4	Line 15E, 22+50N to depth of 300 to 350 feet
DDH No. 5	Line 20E, 24N to depth of 300 to 350 feet
DDH No. 6	Line 20E, 15N to depth of 300 to 350 feet
DDH No. 7	Line 15E, 16+50N to depth of 250 to 300 feet

If copper mineralization, in concentrations of economic interest are intersected in any of these holes, it is possible that some of the anomalies of lower magnitude, or of more limited extent, may have to be considered of interest.

McPHAR GEOPHYSICS LIMITED

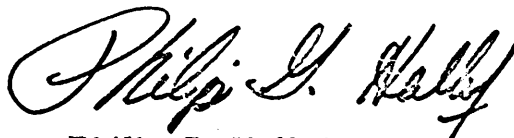

Philip G. Hallof,
Geophysicist.

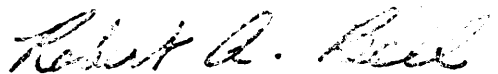

Robert A. Bell,
Geologist.

Dated: September 26, 1966

McPHAR GEOPHYSICS LIMITED

INDUCED POLARIZATION AND RESISTIVITY SURVEY

NOTE: CONTOURS AT LOGARITHMIC MULTIPLES OF 10-15-20-30-50-75-100

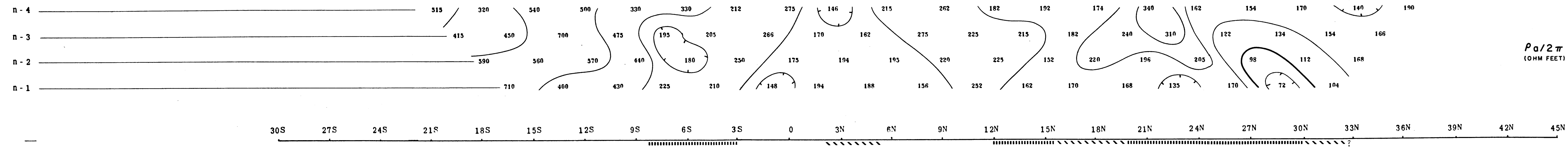
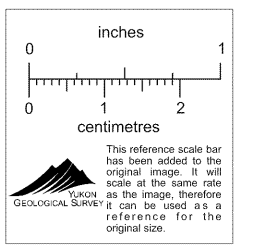
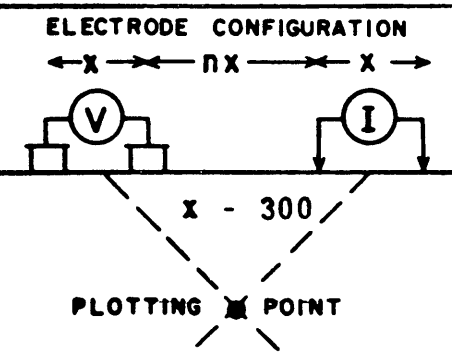

$P_a/2\pi$
(OHM FEET)

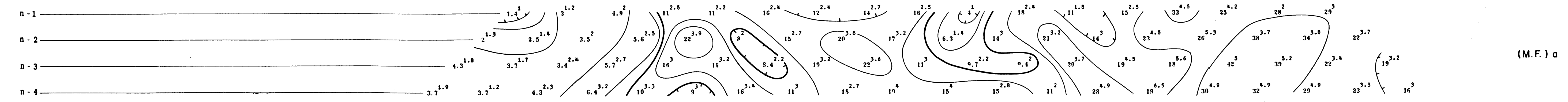

(M.F.) a

CANEX AERIAL EXPLORATION LTD.

GRANITE MTN. PROSPECT (VENTURE 79) WHITEHORSE M.D. - YUKON

Scale—One inch = 300 Feet

NOTE: LOGARITHMIC CONTOUR INTERVAL

SURFACE PROJECTION OF ANOMALOUS ZONES
DEFINITE
PROBABLE
POSSIBLE

FREQUENCY 0.01478 CPS
DATE SURVEYED AUG/68
APPROVED
DATE 9/7/68

LINE NO.-30E

McPHAR GEOPHYSICS LIMITED

INDUCED POLARIZATION AND RESISTIVITY SURVEY

NOTE: CONTOURS AT LOGARITHMIC MULTIPLES OF 10-15-20-30-50-75-100

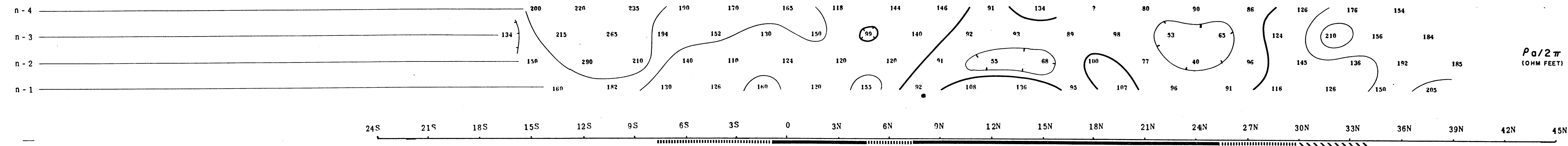
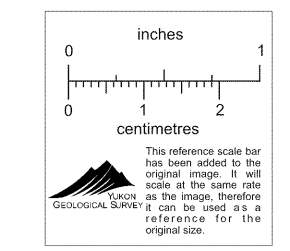
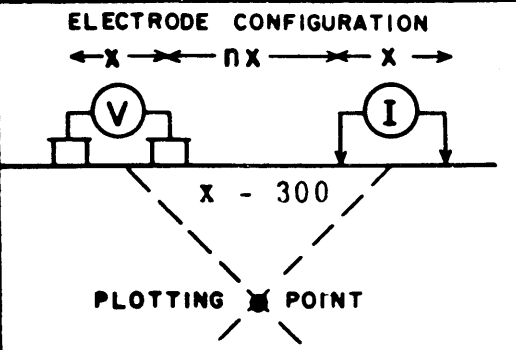

$\rho_a / 2\pi$
(OHM FEET)

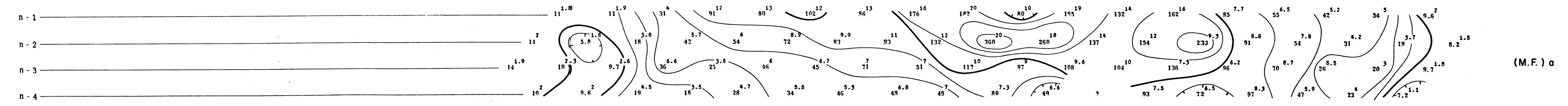

(M.F.) α

CANEX AERIAL EXPLORATION LTD.

GRANITE MTN. PROSPECT (VENTURE 79) WHITEHORSE M.D. - YUKON

Scale - One inch = 300 Feet
NOTE LOGARITHMIC CONTOUR INTERVAL

SURFACE PROJECTION OF ANOMALOUS ZONES
DEFINITE
PROBABLE
POSSIBLE

FREQUENCY 0.318 50 C.P.S.
DATE SURVEYED AUG/66
APPROVED
DATE 8/21/66

LINE NO.-20E

NOTE: CONTOURS AT LOGARITHMIC MULTIPLES OF 10-15-20-30-50-75-100

McPHAR GEOPHYSICS LIMITED

INDUCED POLARIZATION AND RESISTIVITY SURVEY

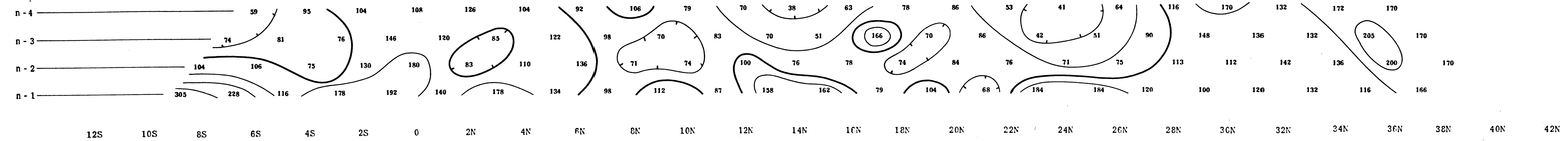
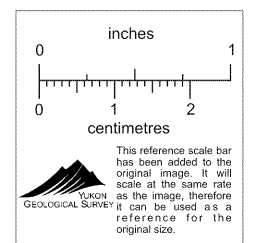
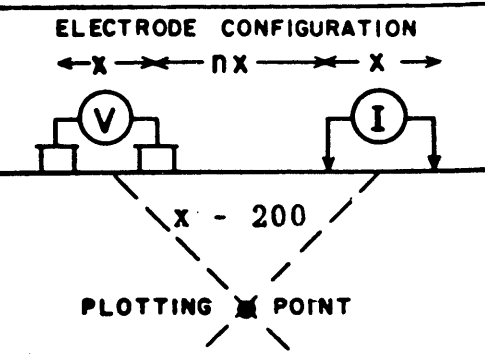

$\rho_a / 2\pi$
(OHM FEET)

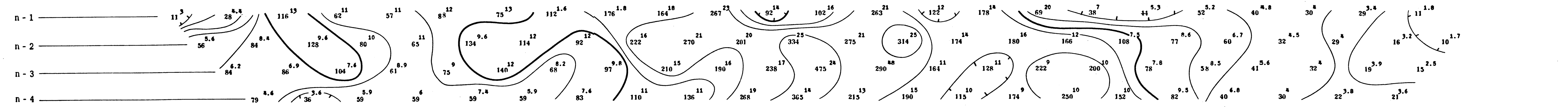

(M.F.) α

CANEX AERIAL EXPLORATION LTD.

GRANITE MTN. PROSPECT (VENTURE 79) WHITEHORSE M.D. - YUKON

Scale—One inch= 200 Feet

NOTE LOGARITHMIC CONTOUR INTERVAL

SURFACE PROJECTION OF ANOMALOUS ZONES
DEFINITE
PROBABLE
POSSIBLE

FREQUENCY 0.8-50 C.P.S.
DATE SURVEYED AUG/66
APPROVED
DATE 8/21/66

LINE NO.-20 E

NOTE: CONTOURS AT LOGARITHMIC MULTIPLES OF 10-15-20-30-50-75-100

McPHAR GEOPHYSICS LIMITED

INDUCED POLARIZATION AND RESISTIVITY SURVEY

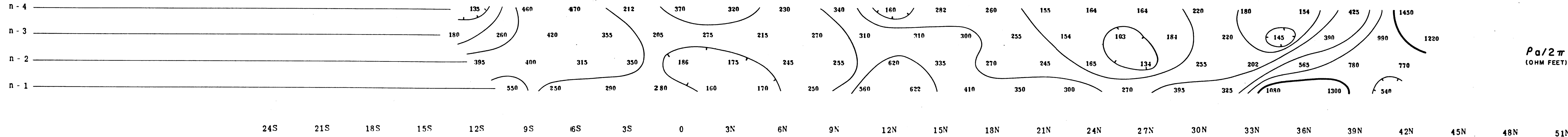
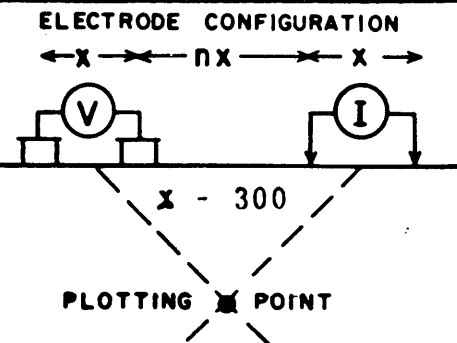
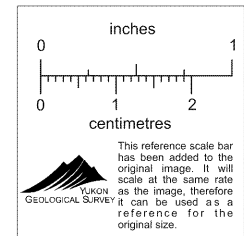

$\rho_a / 2\pi$
(OHM FEET)

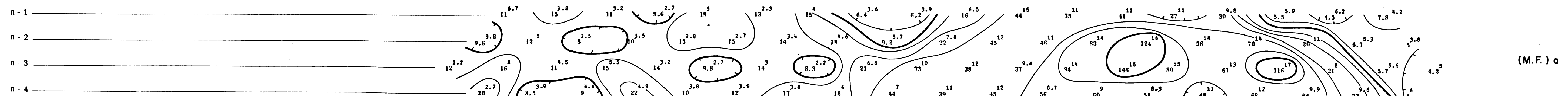

(M.F.) a

CANEX AERIAL EXPLORATION LTD.

GRANITE MTN. PROSPECT (VENTURE 79) WHITEHORSE M.D. - YUKON

Scale—One inch= 300 Feet

NOTE: LOGARITHMIC CONTOUR INTERVAL

SURFACE PROJECTION OF ANOMALOUS ZONES

- DEFINITE
- PROBABLE
- POSSIBLE

FREQUENCY 0.318 50 C.P.S.

DATE SURVEYED AUG/66

APPROVED

DATE 9/21/66

LINE NO.-10E

McPHAR GEOPHYSICS LIMITED

INDUCED POLARIZATION AND RESISTIVITY SURVEY

NOTE: CONTOURS AT LOGARITHMIC MULTIPLES OF 10-15-20-30-50-75-100

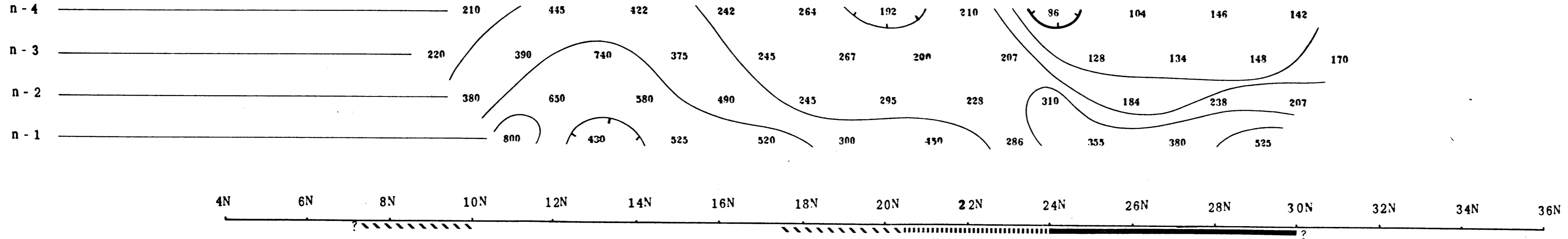
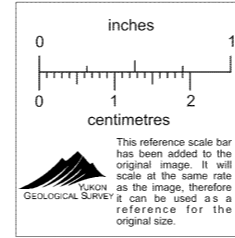
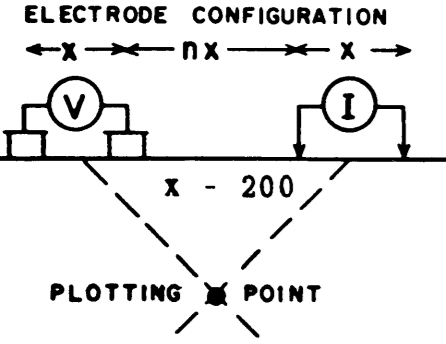

$\rho_a/2\pi$
(OHM FEET)

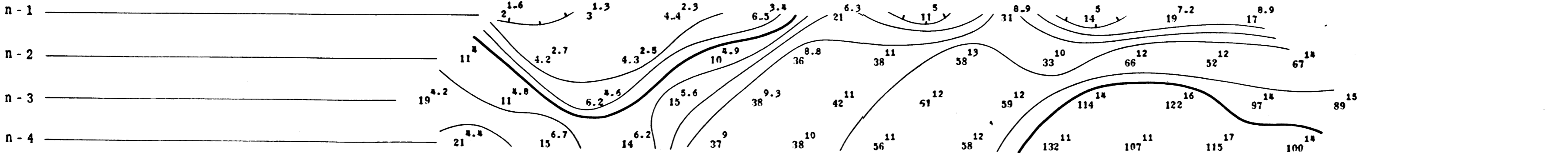

(M.F.) a

CANEX AERIAL EXPLORATION LTD.

GRANITE MTN. PROSPECT (VENTURE 79) WHITEHORSE M.D. - YUKON

Scale - One inch = 200 Feet

NOTE LOGARITHMIC CONTOUR INTERVAL

SURFACE PROJECTION OF ANOMALOUS ZONES
DEFINITE
PROBABLE
POSSIBLE

FREQUENCY 0.318 5.0 C.P.S.
DATE SURVEYED AUG/66
APPROVED
DATE 9/21/66

LINE NO.- IOE

McPHAR GEOPHYSICS LIMITED

INDUCED POLARIZATION AND RESISTIVITY SURVEY

NOTE: CONTOURS AT LOGARITHMIC MULTIPLES OF 10-15-20-30-50-75-100

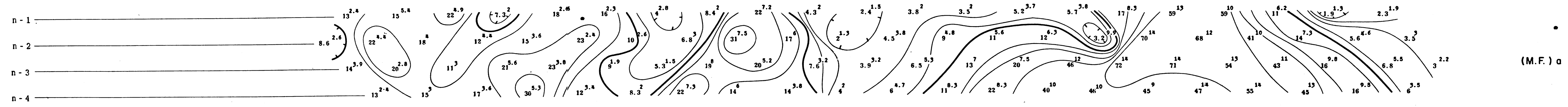
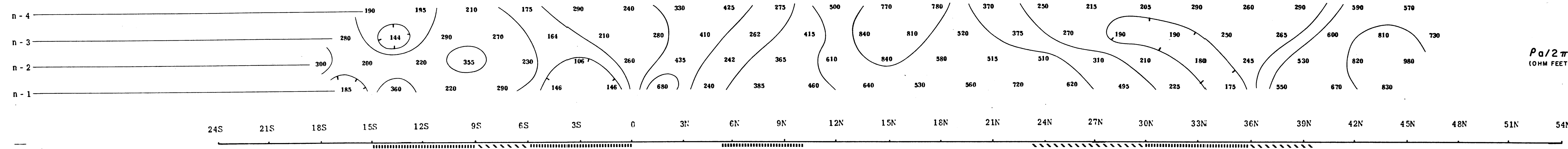
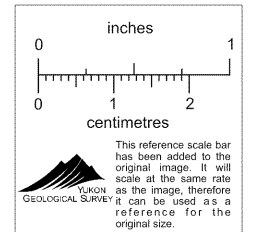
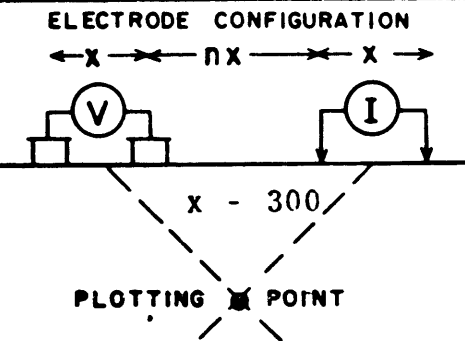

CANEX AERIAL EXPLORATION LTD.

GRANITE MTN. PROSPECT (VENTURE 79) WHITEHORSE M.D. - YUKON

Scale - One inch = 300 Feet

NOTE: LOGARITHMIC CONTOUR INTERVAL

SURFACE PROJECTION OF ANOMALOUS ZONES
DEFINITE
PROBABLE
POSSIBLE

FREQUENCY 318 HERTZ
DATE SURVEYED AUG/66
APPROVED
DATE 9/21/66

LINE NO.-5E

McPHAR GEOPHYSICS LIMITED

INDUCED POLARIZATION AND RESISTIVITY SURVEY

NOTE: CONTOURS AT LOGARITHMIC MULTIPLES OF 10-15-20-30-50-75-100

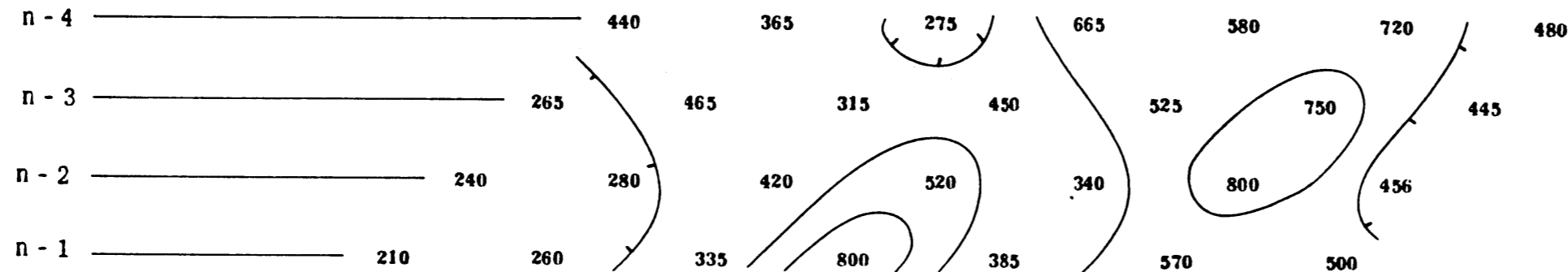
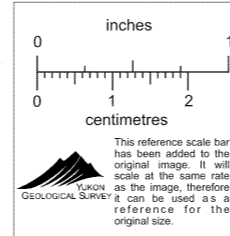
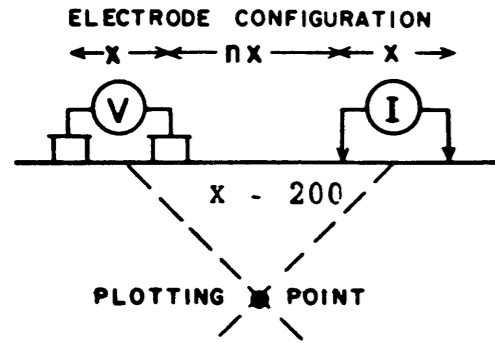

0 2N 4N 6N 8N 10N 12N 14N 16N 18N 20N 22N 24N

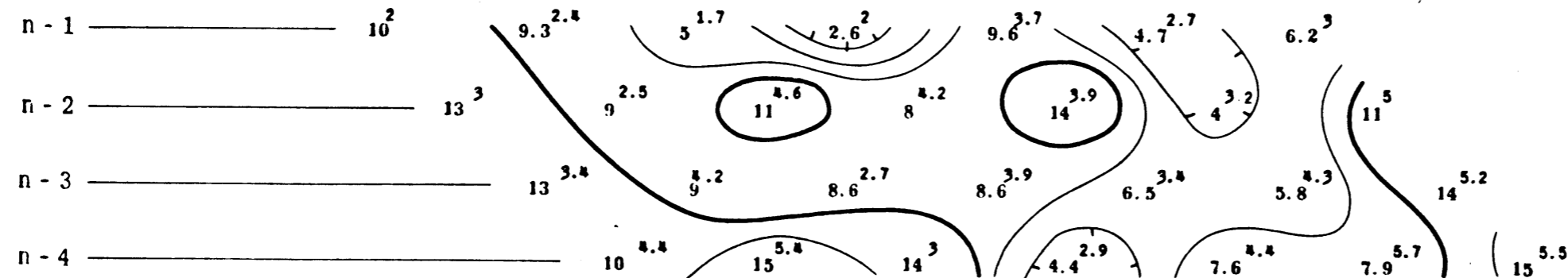

CANEX AERIAL EXPLORATION LTD.

GRANITE MTN. PROSPECT (VENTURE 79) WHITEHORSE M.D. - YUKON

Scale - One inch = 200 Feet

NOTE LOGARITHMIC CONTOUR INTERVAL

SURFACE PROJECTION OF ANOMALOUS ZONES

- DEFINITE
- PROBABLE
- POSSIBLE

FREQUENCY 0.31850 C.P.S.

DATE SURVEYED AUG/66

APPROVED *[Signature]*

DATE 12/9/66

LINE NO.-5 E

McPHAR GEOPHYSICS LIMITED

INDUCED POLARIZATION AND RESISTIVITY SURVEY

NOTE: CONTOURS AT LOGARITHMIC MULTIPLES OF 10-15-20-30-50-75-100

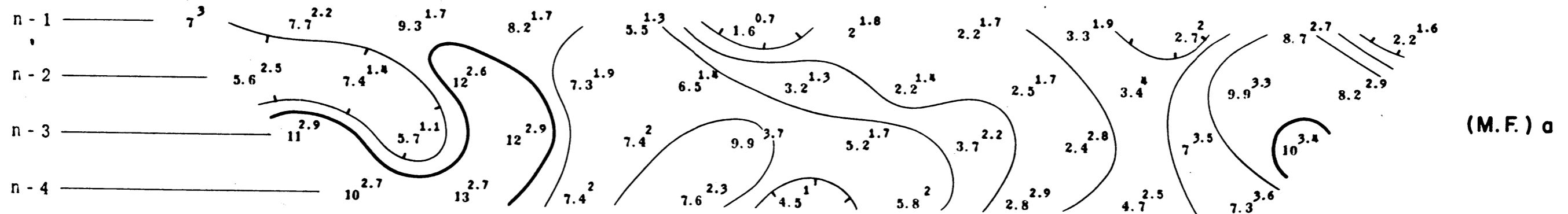
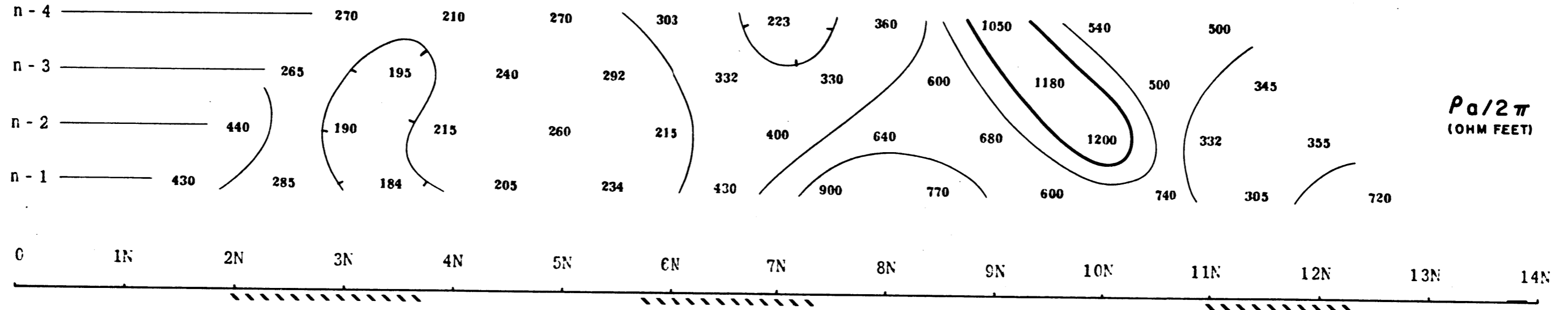
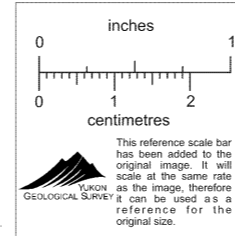
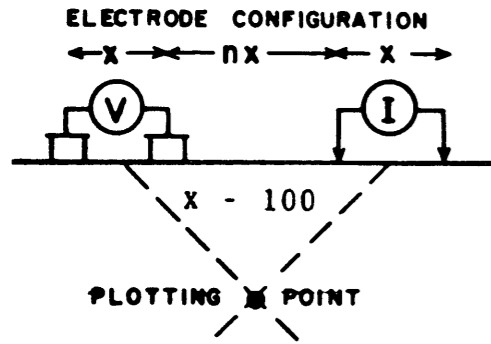

CANEX AERIAL EXPLORATION LTD.

GRANITE MTN. PROSPECT (VENTURE 79) WHITEHORSE M.D. - YUKON

Scale - One inch = 100 Feet

NOTE: LOGARITHMIC CONTOUR INTERVAL

SURFACE PROJECTION OF ANOMALOUS ZONES

- DEFINITE
- PROBABLE
- POSSIBLE

FREQUENCY 0.31850 C.P.S.

DATE SURVEYED AUG / 68

APPROVED /s/ [Signature]

DATE 9/12/68

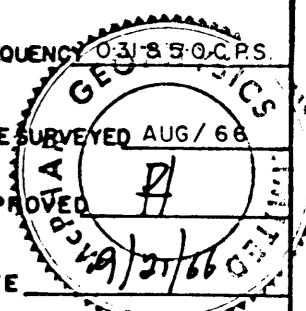

LINE NO.-5E

McPHAR GEOPHYSICS LIMITED

INDUCED POLARIZATION AND RESISTIVITY SURVEY

NOTE: CONTOURS AT LOGARITHMIC MULTIPLES OF 10-15-20-30-50-75-100

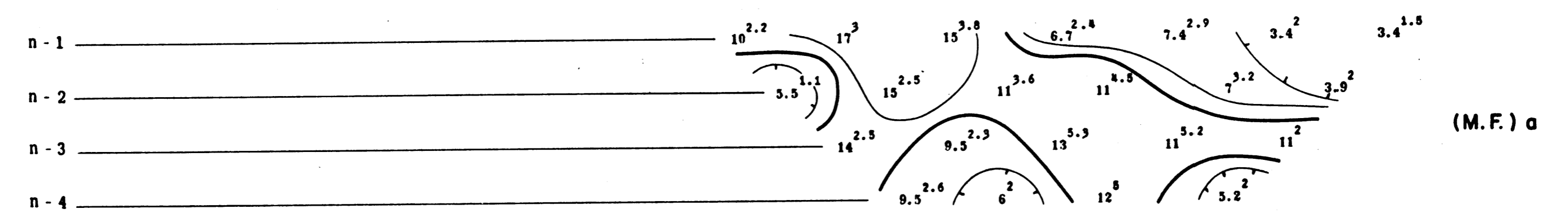
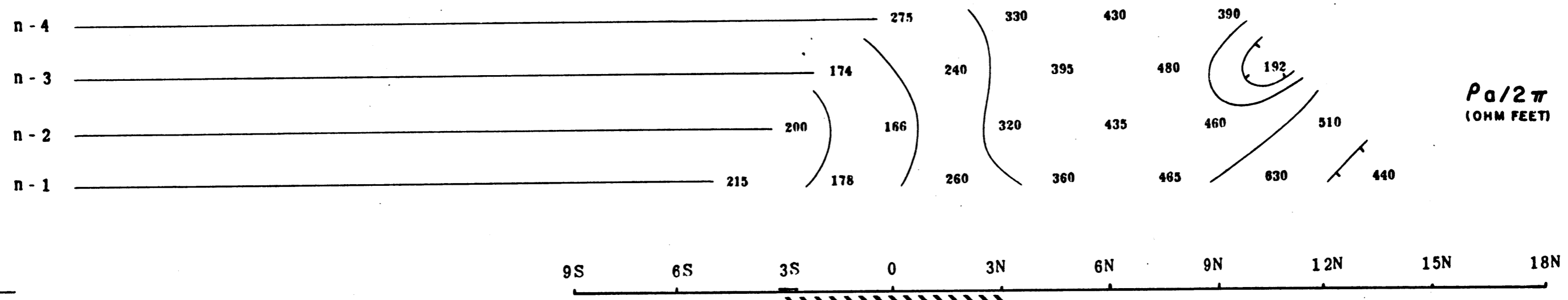
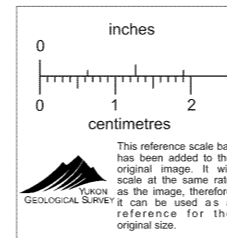
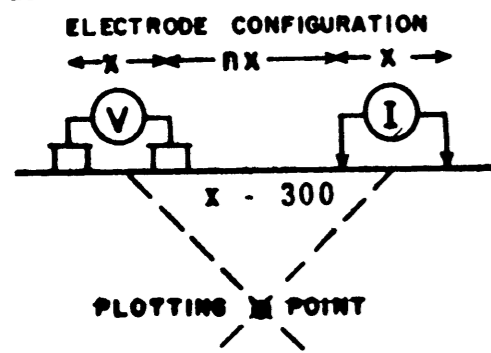

CANEX AERIAL EXPLORATION LTD.

GRANITE MTN. PROSPECT (VENTURE 79) WHITEHORSE M.D. - YUKON

Scale - One inch = 300 Feet

NOTE: LOGARITHMIC CONTOUR INTERVAL

SURFACE PROJECTION OF ANOMALOUS ZONES

DEFINITE

PROBABLE

POSSIBLE

FREQUENCY 0.318 5.0 C.P.S.

DATE SURVEYED AUG / 66

APPROVED

DATE 09/22/66

1 IN 10 2+50E

McPHAR GEOPHYSICS LIMITED
 INDUCED POLARIZATION AND RESISTIVITY SURVEY

NOTE: CONTOURS AT
 LOGARITHMIC MULTIPLES
 OF 10-15-20-30-50-75-100

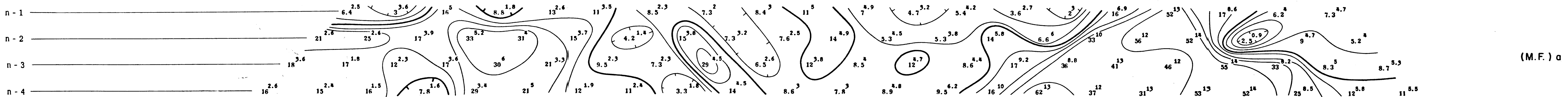
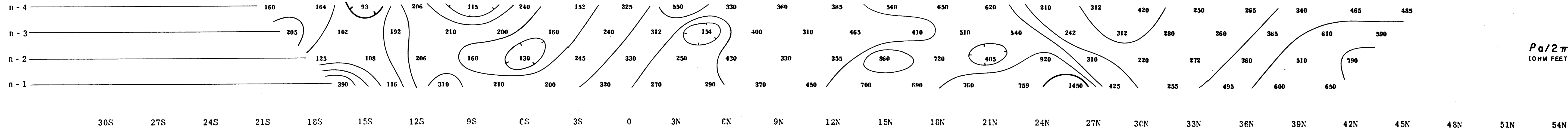
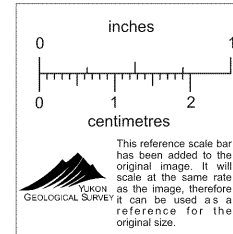
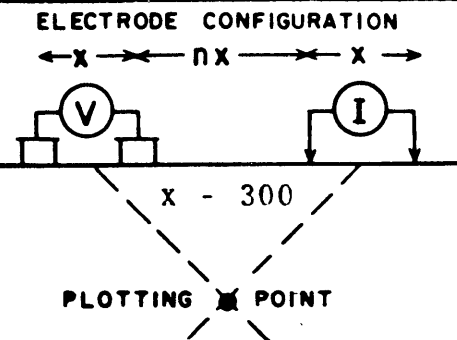

CANEX AERIAL EXPLORATION LTD.

GRANITE MTN. PROSPECT (VENTURE 79) WHITEHORSE M.D. - YUKON

Scale—One inch= 300 Feet

NOTE LOGARITHMIC CONTOUR INTERVAL

SURFACE PROJECTION
 OF ANOMALOUS ZONES

- DEFINITE
- PROBABLE
- POSSIBLE

FREQUENCY 0.318 50 C.P.S.

DATE SURVEYED AUG/66

APPROVED

DATE 9/3/66

LINE NO.-0

NOTE: CONTOURS AT LOGARITHMIC MULTIPLES OF 10-15-20-30-50-75-100

McPHAR GEOPHYSICS LIMITED

INDUCED POLARIZATION AND RESISTIVITY SURVEY

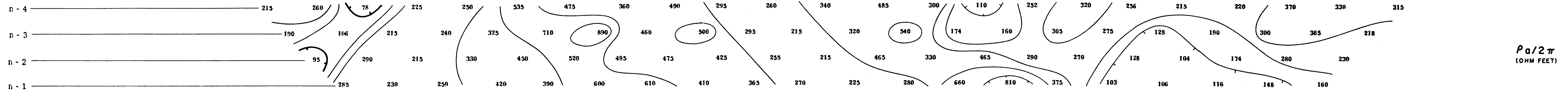
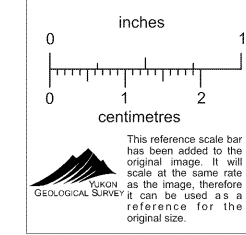
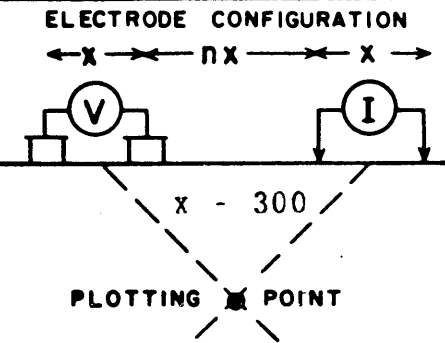

$\rho_a / 2\pi$
(OHM FEET)

30S 27S 24S 21S 18S 15S 12S 9S 6S 3S 0 3N 6N 9N 12N 15N 18N 21N 24N 27N 30N 33N 36N 39N 42N 45N 48N 51N 54N

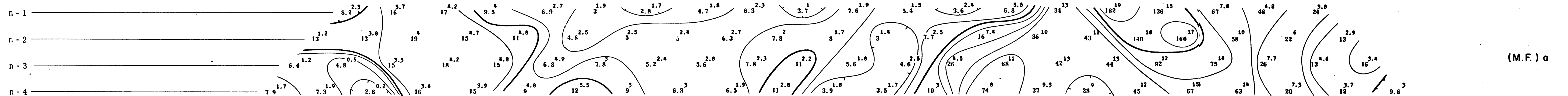

(M.F.) a

CANEX AERIAL EXPLORATION LTD.

GRANITE MTN. PROSPECT (VENTURE 79) WHITEHORSE M.D. - YUKON

Scale—One inch= 300 Feet

NOTE: LOGARITHMIC CONTOUR INTERVAL

SURFACE PROJECTION OF ANOMALOUS ZONES

- DEFINITE
- PROBABLE
- POSSIBLE

FREQUENCY 0.318 50 C.P.S.
DATE SURVEYED AUG/66
APPROVED
DATE 9/2/66

LINE NO.-10W

McPHAR GEOPHYSICS LIMITED

INDUCED POLARIZATION AND RESISTIVITY SURVEY

NOTE: CONTOURS AT LOGARITHMIC MULTIPLES OF 10-15-20-30-50-75-100

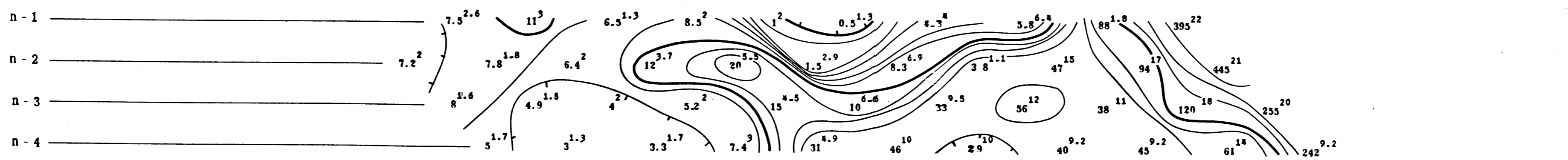
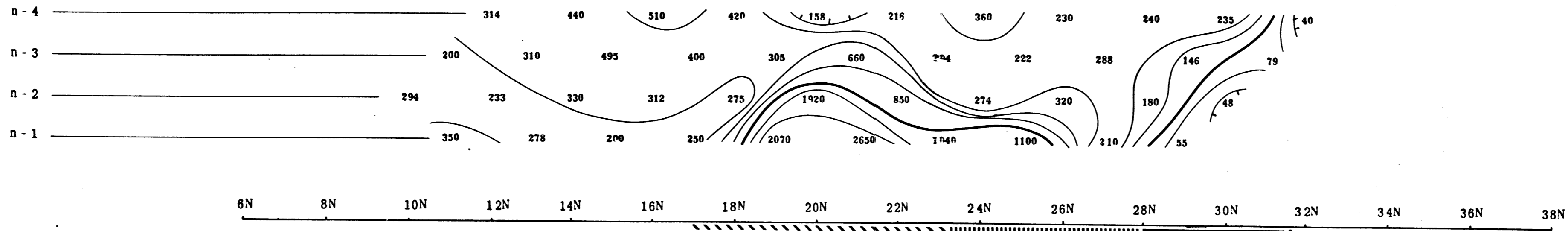
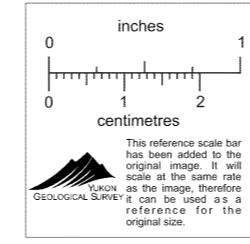
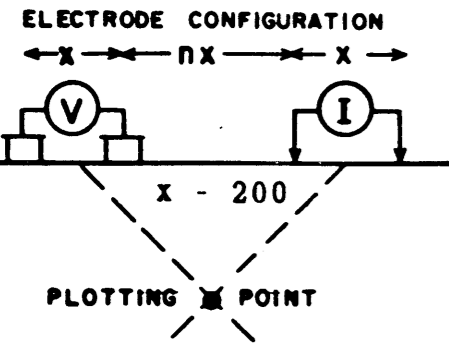

$\rho a / 2\pi$
(OHM FEET)

(M.F.) α

CANEX AERIAL EXPLORATION LTD.

GRANITE MTN. PROSPECT (VENTURE 79) WHITEHORSE M.D - YUKON

Scale - One inch = 200 Feet

NOTE LOGARITHMIC CONTOUR INTERVAL

SURFACE PROJECTION OF ANOMALOUS ZONES

- DEFINITE
- PROBABLE
- POSSIBLE

FREQUENCY 0.318 5.0 CPS

DATE SURVEYED AUG/66

APPROVED P

DATE 9/21/66

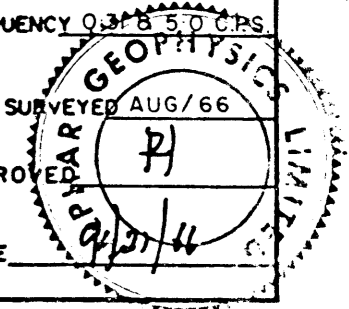

LINE NO.-10 W

NOTE: CONTOURS AT LOGARITHMIC MULTIPLES OF 10-15-20-30-50-75-100

McPHAR GEOPHYSICS LIMITED

INDUCED POLARIZATION AND RESISTIVITY SURVEY

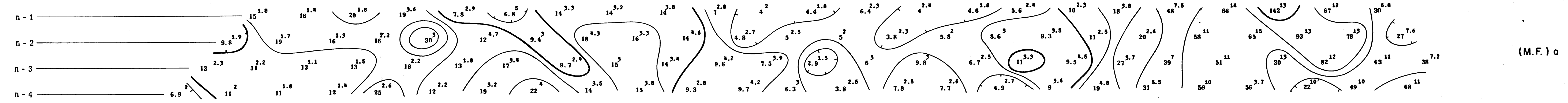
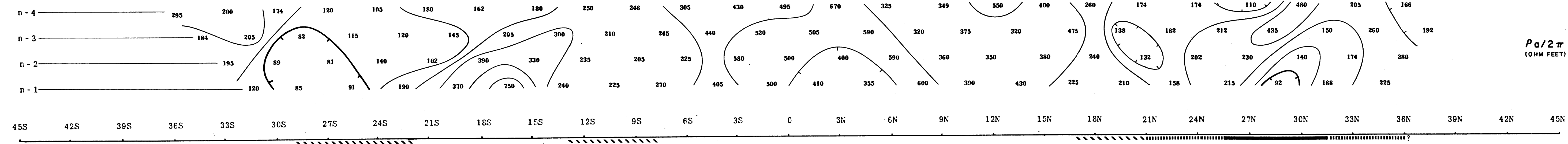
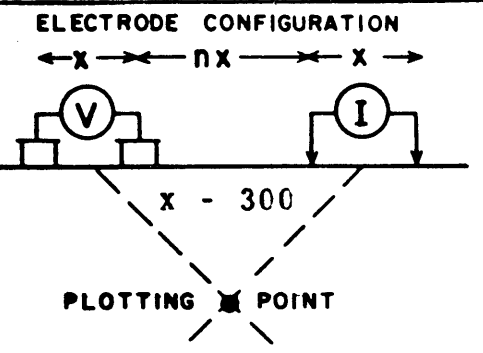
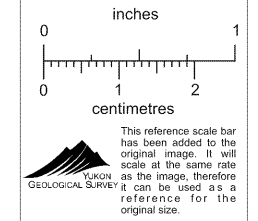

SURFACE PROJECTION OF ANOMALOUS ZONES
DEFINITE
PROBABLE
POSSIBLE

CANEX AERIAL EXPLORATION LTD.

GRANITE MTN. PROSPECT (VENTURE 79) WHITEHORSE M.D. - YUKON

Scale—One inch = 300 Feet
NOTE: LOGARITHMIC CONTOUR INTERVAL

FREQUENCY 0.328 50 C.P.S.
DATE SURVEYED AUG/68
APPROVED
DATE 9/21/68

LINE NO-15 W

McPHAR GEOPHYSICS LIMITED

INDUCED POLARIZATION AND RESISTIVITY SURVEY

NOTE: CONTOURS AT LOGARITHMIC MULTIPLES OF 10-15-20-30-50-75-100

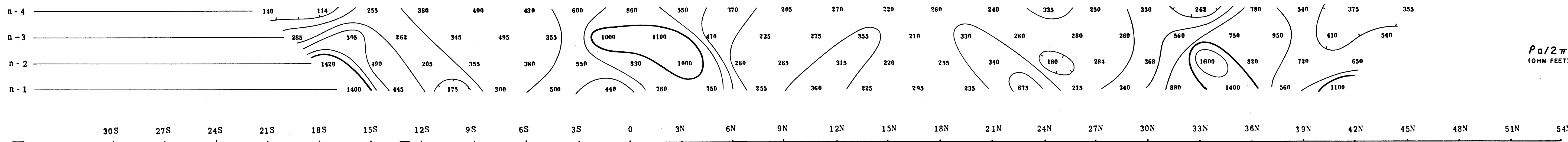
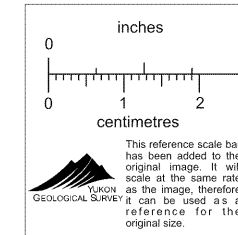
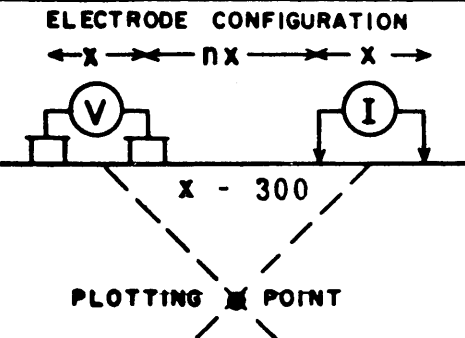

$\rho_a / 2\pi$
(OHM FEET)

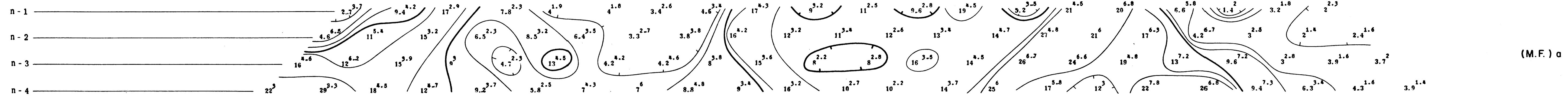

(M.F.) a

CANEX AERIAL EXPLORATION LTD.

GRANITE MTN. PROSPECT (VENTURE 79) WHITEHORSE M.D. - YUKON

Scale - One inch = 300 Feet

NOTE LOGARITHMIC CONTOUR INTERVAL

SURFACE PROJECTION OF ANOMALOUS ZONES

- DEFINITE
- PROBABLE
- POSSIBLE

FREQUENCY 0.318 50 C.P.S.

DATE SURVEYED AUG/66

APPROVED

DATE

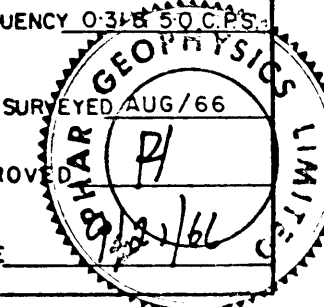

LINE NO.-20W

NOTE: CONTOURS AT LOGARITHMIC MULTIPLES OF 10-15-20-30-50-75-100

McPHAR GEOPHYSICS LIMITED
INDUCED POLARIZATION AND RESISTIVITY SURVEY

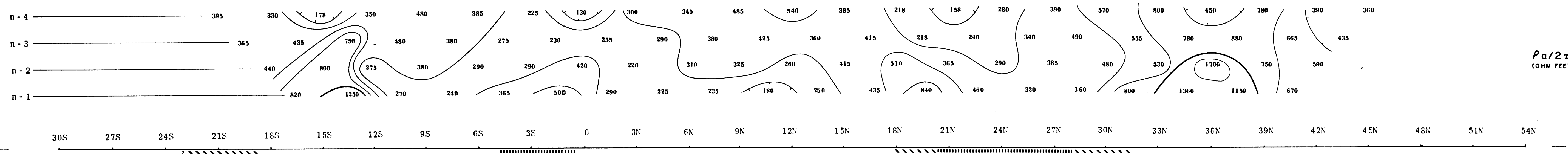
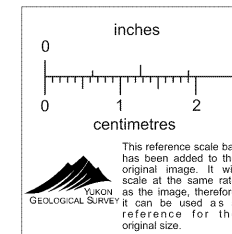
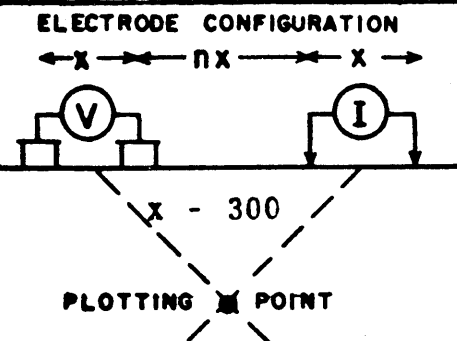

$\rho_a / 2\pi$
(OHM FEET)

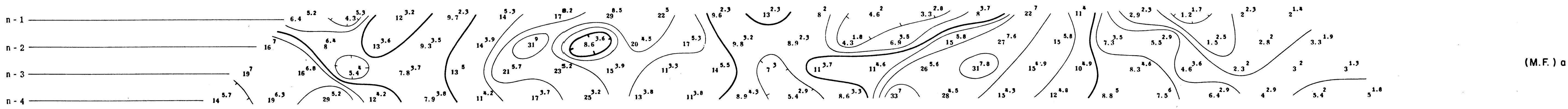

(M.F.) a

SURFACE PROJECTION OF ANOMALOUS ZONES
DEFINITE
PROBABLE
POSSIBLE

CANEX AERIAL EXPLORATION LTD.

GRANITE MTN. PROSPECT (VENTURE 79) WHITEHORSE M.D. - YUKON

Scale—One inch= 300 Feet
NOTE LOGARITHMIC CONTOUR INTERVAL

FREQUENCY 0.25/100 CPS
DATE SURVEYED AUG/66
APPROVED
DATE 10/12/66

LINE NO.-25 W

NOTE: CONTOURS AT LOGARITHMIC MULTIPLES OF 10-15-20-30-50-75-100

McPHAR GEOPHYSICS LIMITED

INDUCED POLARIZATION AND RESISTIVITY SURVEY

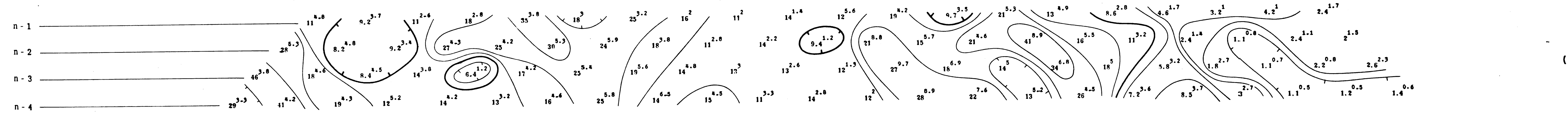
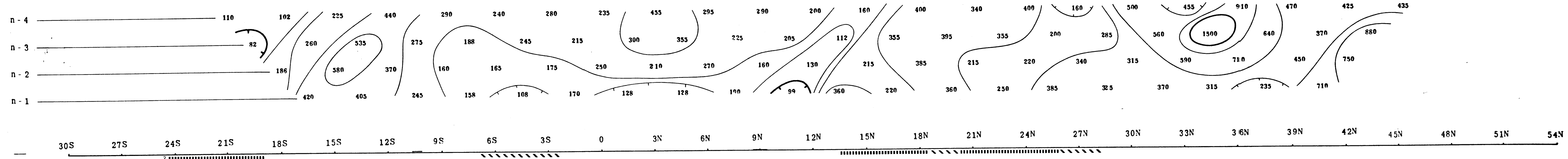
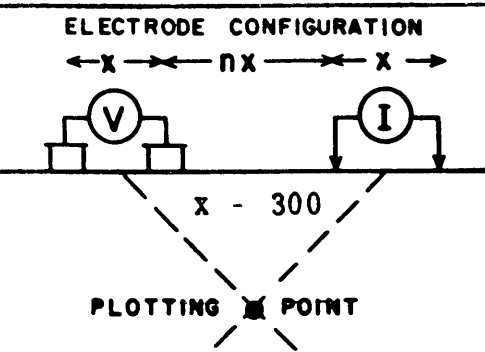
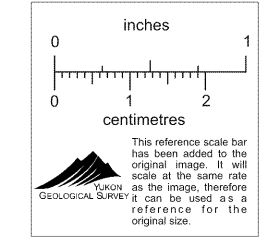

CANEX AERIAL EXPLORATION LTD.

GRANITE MTN. PROSPECT (VENTURE 79) WHITEHORSE M.D. - YUKON

Scale—One inch= 300 Feet

NOTE: LOGARITHMIC CONTOUR INTERVAL

SURFACE PROJECTION OF ANOMALOUS ZONES

- DEFINITE
- PROBABLE
- POSSIBLE

FREQUENCY 0.25-50 Hz

DATE SURVEYED AUG/66

APPROVED

DATE 9/21/66

LINE NO.-30W

McPHAR GEOPHYSICS LIMITED

INDUCED POLARIZATION AND RESISTIVITY SURVEY

NOTE: CONTOURS AT LOGARITHMIC MULTIPLES OF 10-15-20-30-50-75-100

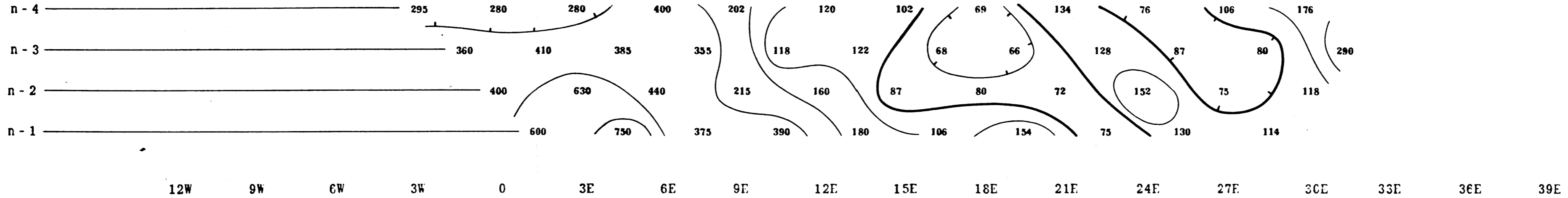
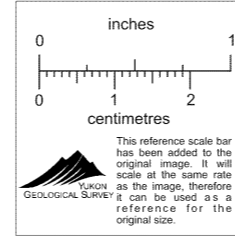
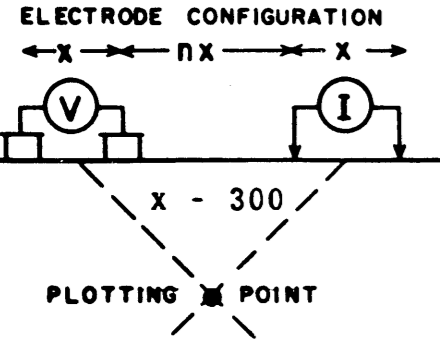

$\rho a / 2\pi$
 (OHM FEET)

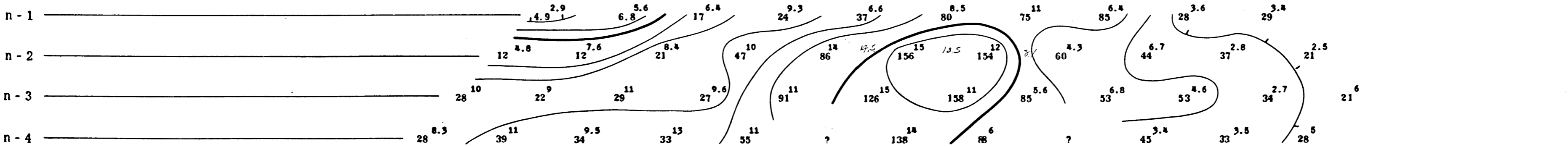

(M.F.) σ

CANEX AERIAL EXPLORATION LTD.

GRANITE MTN. PROSPECT (VENTURE 79) WHITEHORSE M.D. - YUKON

Scale - One inch = 300 Feet

NOTE LOGARITHMIC CONTOUR INTERVAL

SURFACE PROJECTION OF ANOMALOUS ZONES
 DEFINITE
 PROBABLE
 POSSIBLE

FREQUENCY 0.3-8-50 CPS
 DATE SURVEYED AUG/68
 APPROVED
 DATE 9/2/68

LINE NO.-22 N

McPHAR GEOPHYSICS LIMITED

INDUCED POLARIZATION AND RESISTIVITY SURVEY

NOTE: CONTOURS ARE LOGARITHMIC MULTIPLES OF 10-15-20-30-50-75-100

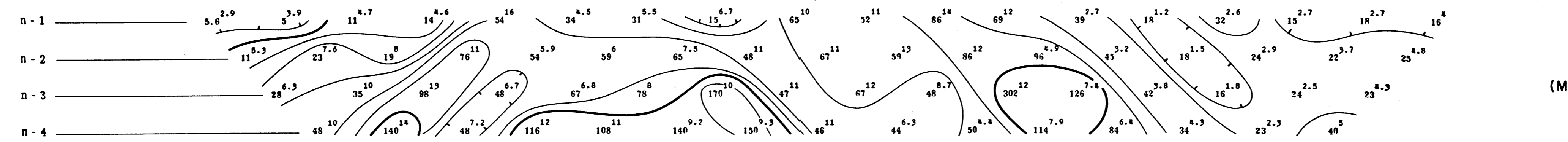
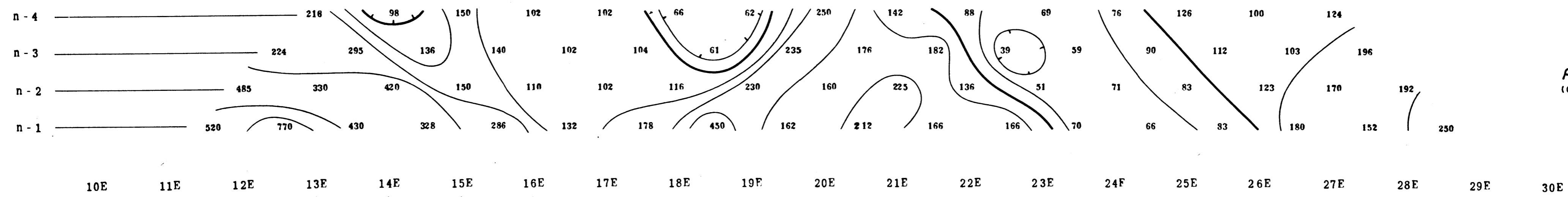
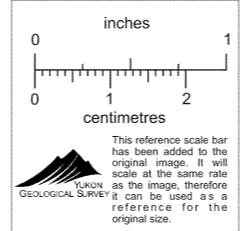
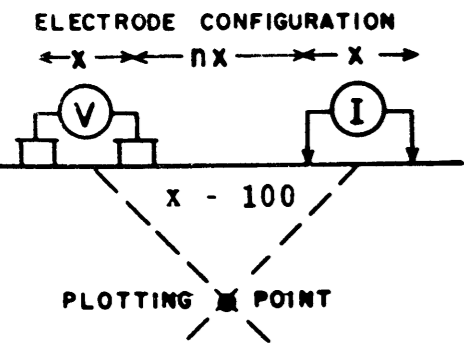

CANEX AERIAL EXPLORATION LTD.

GRANITE MTN. PROSPECT (VENTURE 79) WHITEHORSE M.D. - YUKON

Scale - One inch = 100 Feet

NOTE LOGARITHMIC CONTOUR INTERVAL

SURFACE PROJECTION OF ANOMALOUS ZONES
 DEFINITE
 PROBABLE
 POSSIBLE

FREQUENCY 0.318 5.0 C.P.S.

DATE SURVEYED AUG 76

APPROVED

DATE

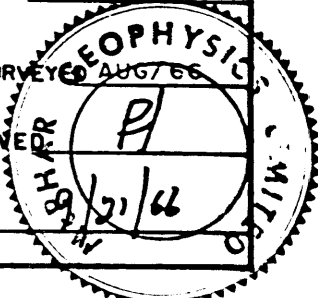

LINE NO.-22N